

CRASH 'N



OPERATION MAINTENANCE SERVICE MANUAL

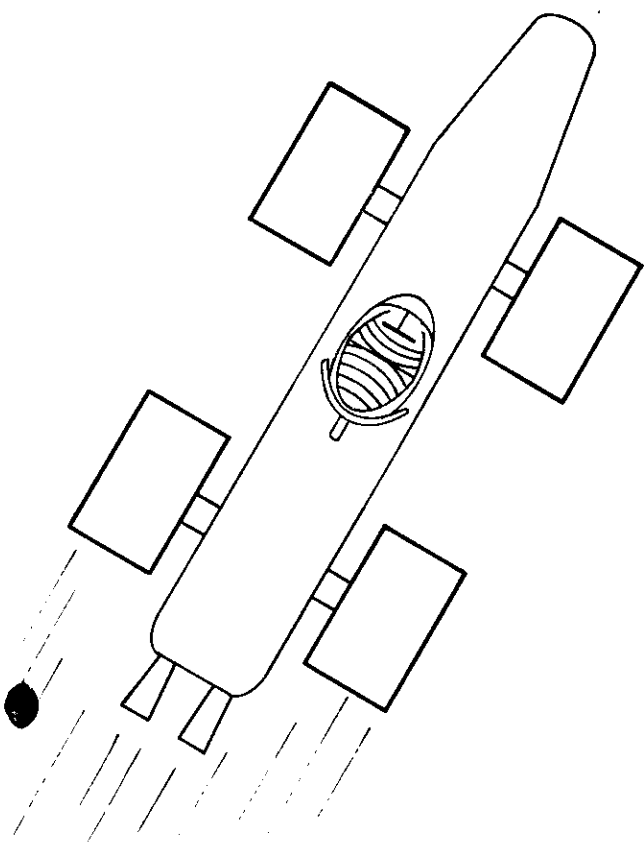

Table of Contents

SUBJECT	Page		Page
I. INTRODUCTION	1	IV. INSTALLATION INSTRUCTIONS	21
1.1 Physical Description of Game	"	4.1 Unpacking Instructions	"
1.2 Brief Description of Play	"	4.1.1 Examination for Shipping Damage	"
II. SPECIFICATIONS	3	4.1.2 Mechanical Inspection	"
2.1 General	"	4.2 Energizing the Game	"
2.2 Electrical	"	4.2.1 Application of AC Power	"
2.3 Environmental	"	4.2.2 Check on Operation of Interlock Switch	"
2.4 Owner/Operator Options for Structuring of Play	"	4.3 Game Structuring	"
2.5 Accessories Available on Separate Order	"	4.3.1 Coin Credit Option	"
III. THEORY OF OPERATION	5	4.3.2 Length of Game Time Option	"
3.1 Functional Description of Game	"	4.3.3 Bonus Credit Option	"
3.2 General Information	"	4.3.4 Adjustment of Speaker Volumes and Pitches	"
3.2.1 Energizing the Game	"	4.4 Functional Check of Game Operations	23
3.2.2 TV Monitor	"	4.4.1 Attract Mode	"
3.2.3 Picture on TV Screen	"	4.4.2 Obtaining Credits	24
3.3 Game Sequence	"	4.4.3 First Play Sequence	"
3.3.1 Operating Modes	"	4.4.4 Game Time Elapsed, With Credit Remaining	"
3.3.2 Attract Mode	"	4.4.5 Second Play Sequence	25
3.3.3 Game Sequence in Play Mode	"	V. MAINTENANCE AND ADJUSTMENTS	27
3.3.4 Owner/Operator Options	"	5.1 Routine Maintenance	"
3.4 Detailed Technical Description of Operation	8	5.1.1 Cleaning	"
3.4.1 General Comments	"	5.1.2 Lubrication	"
3.4.2 TV Synchronization Information	"	5.2 Adjustments on TV Monitor	"
3.4.3 Playfield Generation	9	VI. TROUBLESHOOTING AND REPAIR	29
3.4.4 Coin Validation	"	6.1 General Procedure	"
3.4.5 Coin Counter Circuit	"	6.1.1 Identifying the Trouble Area	"
3.4.6 "Q" Latch	10	6.1.2 Locating the Trouble Cause	"
3.4.7 "Start" Push Button Switches	"	6.1.3 Correcting the Trouble Cause	"
3.4.8 Credit Accumulator and Lamp Drivers for "Start" Push Buttons	"	6.1.4 Verifying Correct Game Operation	"
3.4.9 Game Timer	11	6.2 Test Equipment	30
3.4.10 Score Registers and Score Display	"	6.2.1 Basic Test Equipment	"
3.4.11 Bonus Credit Circuitry	"	6.2.2 Optional Test Equipment	31
3.4.12 White/Black Flag Generator, Hit Detectors and Scoring Signal Circuit	12	6.3 Specific Troubleshooting Information	"
3.4.13 Gas Pedal Signals and Processing of Acceleration Signals	13	6.3.1 Antenna Static Modification	"
3.4.14 Car Steering Signals and Steering Processors	15	6.3.2 TV Monitor	32
3.4.15 Motion Code PROM	"	6.3.3 Coin Mechanism	"
3.4.16 Horizontal and Vertical Motion Counters	16	VII. SCHEMATICS, DRAWINGS, AND PARTS LISTS	35
3.4.17 Car Reset Circuit	18		
3.4.18 Car Video Processors	"		
3.4.19 Video Summing Circuit	"		
3.4.20 Engine Sound Synthesizers	"		
3.4.21 Crash and Skid Detectors	"		
3.4.22 Screech and Crunch Sound Synthesizers	19		
3.4.23 Sound Summing Circuits	"		
3.4.24 Speaker Driver Stages	"		

II. Specifications

2.1 GENERAL

Cabinet Dimensions: Height 61 inches, Width 31½ in
Depth 30½ inches.

Cabinet Weight: 289 lbs.

TV Monitor: Motorola XM701, black and white, with
23-inch screen.

Coin Mechanisms: Two identical mechanisms that
accept quarters only; coins may
be deposited in either mech-
anism to initiate play.

Cash Box: Removable, located behind locked access
door to coin assembly.

Power Cord: Approximately 6 ft. long, extending
from rear of cabinet and having
grounded three-prong plug for
conventional wall outlet.

2.2 ELECTRICAL

Power Requirement: Uses conventional wall outlet
providing 60-cycle AC (60-Hz,
single-phase) at 110 volts; power
consumption rated at 94 watts.

Fusing: All fuses located inside cabinet; TV monitor
has two 1-amp fuses and remain-
der of game is protected by a
1.25-amp fuse.

Power Interrupt

Switch: This is a safety switch located inside the game
cabinet. It interrupts AC power
to the game whenever the rear
panel service access door is
unlocked and opened.

2.3 ENVIRONMENTAL

Operating and Storage Temperature Range:
from 32°F to 120°F (ambient
temperature).

Relative Humidity: from 0% to 80% *without*
condensation.

2.4 OWNER/OPERATOR OPTIONS FOR STRUCTURING OF PLAY

- Coin Credit adjustable for either 1 credit/coin or
2 credits/coin.
- Length of Game Time adjustable (from approx-
imately 20 secs. to 2 mins. 50
secs.)
- Bonus Credit either not allowed, or given for
achievement of a specified score
level (selectable in 10-point
increments, from 10 up to a max-
imum of 90).

2.5 ACCESSORIES AVAILABLE ON SEPARATE ORDER

Video Probe: order from ATARI

Universal Test Fixture:
order from ATARI, catalog no.
TF101

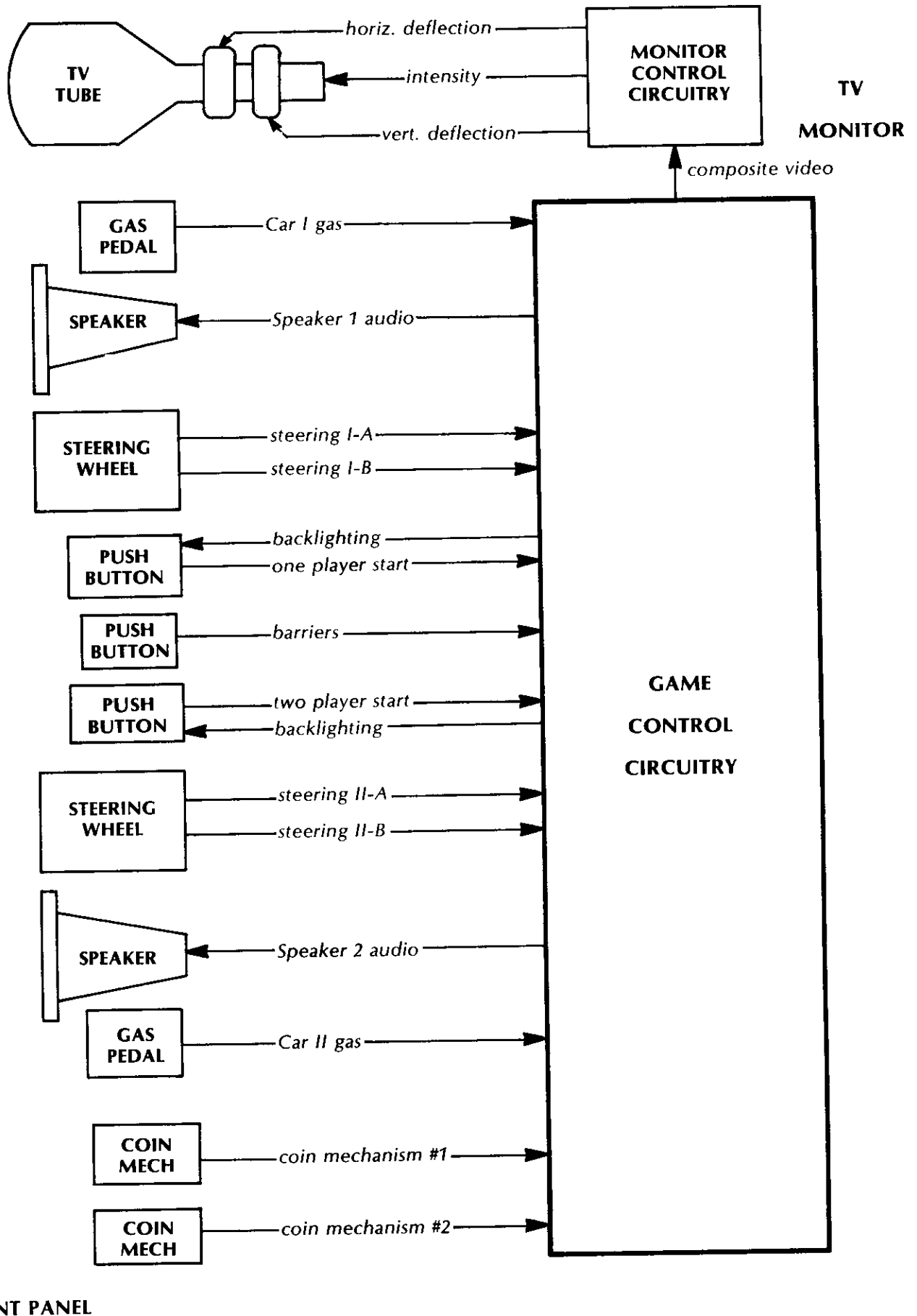

FRONT PANEL

Figure 3-1 Block Diagram of Crash 'N Score Game

in order to initiate game play. The game timer then begins to count down, and play ends when all the game time has elapsed. Details of the game sequence are given below.

(a) *Credit Accumulator.* The Crash 'N Score game features an internal electronic credit accumulator that can store as many as 15 credits. If one or more credits are remaining in this accumulator when game time elapses at the end of a play sequence, then the game stays in the play mode rather than changing over to the attract mode. To initiate a new play sequence, the player need only depress a lighted start push button. However, if no credits are remaining in the credit accumulator, then the game changes over to the attract mode as soon as game time elapses. A player must then deposit money in order to enter credit into the credit accumulator.

(b) *Obtaining Credits.* To change the game over from the attract mode to play mode, a player has to deposit one or more coins into a coin mechanism so that credit will be entered into the credit accumulator. Coins deposited at any time are recognized, but the credit accumulator is not able to store more than 15 credits at any one time. Under 1 credit/coin game structuring, one credit is entered into the coin accumulator each time a player deposits a coin and it clears the coin mechanism; under 2 credits/coin game structuring two credits are entered.

Provided that the game is structured to allow bonus credits, when in the play mode players also can obtain credits by earning scores that reach or exceed certain levels. One credit will be added into the credit accumulator when a player's score reaches the score achievement level set up in the game structuring (for example, 10 points, 20 points, etc.). In a 2-player game each player can earn a bonus credit; this means that a maximum of two bonus credits could be given during a single play sequence in a 2-player game.

(c) *Start Push Buttons and Barriers Push Button.* Neither start push button will be lighted during a play sequence. At other times a start button is lighted only when credit remains in the credit accumulator. The left-of-center push button (engraved with the words ONE PLAYER START) is lighted if one or more credits remain in the credit accumulator, and the right-of-center push button (engraved TWO PLAYER START) also is lighted if two or more credits remain.

Whenever at least one start push button is lighted, the unlighted barriers push button is made operative. If barriers are visible on the TV screen, depressing the barriers push button will cause them to disappear. Conversely, if they are not visible, then depressing the barriers push button will cause them to appear. The barriers push button is only operative when one or both start push buttons are lighted; it is not operative during the attract mode or while the game timer is counting down.

When a player depresses a lighted start push button, the game timer begins to count down and the game responds as follows:

- (1) Both score displays are reset to zero.
- (2) The steering wheel and gas pedal controls are made operative.
- (3) The position of the white car (Car I) is changed; it will appear at the left edge of the screen, halfway between the top and bottom, with the car pointing toward the center of the screen. In a 1-player game the grey car (Car II) disappears. In a 2-player game the grey car's position is changed to the right edge of the screen, halfway between the top and bottom, also with the car pointing toward the center of the screen.
- (4) Each car's engine sound starts to be produced by its speaker. In a 1-player game Speaker 2, the right-hand speaker, does not produce any sound because Car II is not appearing on the TV screen.
- (5) The start push buttons cease to be lighted.

(d) *Car Motion.* Car speed and direction are under player control except for a few seconds after a car runs into an obstacle or into the opponent car. A car goes into a skid whenever it either runs into an oil slick or collides with the opponent car; the amount of car rotation and the distance traveled during a skid both are magnified in direct proportion to the car's speed. Therefore a fast-moving car's motion is more affected than is the motion of a slow-moving car. A car stops for a few seconds whenever it runs into either an unlighted flag or a barrier. If a car runs off the edge of the screen it disappears, but after a few seconds reappears at the opposite edge of the screen and resumes its travel on the playfield. A car's motion is unaffected when it moves through a lighted flag or if it should happen to cross into either score display region on the TV screen.

(e) *Game Sounds.* Sounds begin to be produced as soon as a lighted start push button has been depressed, and cease after the game time elapses. Throughout play the engine sounds are heard separately for each car, with Car I's engine sound being produced by Speaker 1 (on the left side of the cabinet) and Car II's sound by Speaker 2 (on the right). The engine sound will vary from "idle" speed, when the car is motionless and the player is not depressing the gas pedal, up through progressively higher-speed engine sounds as the car responds to gas pedal commands by moving faster and faster on the playfield. Other sounds produced separately for each car at various times during play can include the tire screech sound and the crunch sound.

The tire screech sound is produced whenever the car runs into an oil slick obstacle and whenever a car collides with the opponent car. The crunch sound is produced whenever a car runs into either an unlighted flag obstacle or a barrier obstacle. Two additional game sounds can be produced by Speaker 1 only: a brief buzzing sound and a beeping sound. The buzzing sound is heard each time a point is scored

by either car. For example, if Car II drove through a lighted flag having a numeral "3", then Speaker 1 would produce three brief buzzing sounds. If the game is structured to allow earning bonus credits, then Speaker 1 will produce a beeping sound as soon as either car's score reaches the preselected achievement level (for example, 10 points, 20 points, etc.).

(f) *End of Play.* When the game timer finishes counting down, play ends. The final scores from the just-completed play sequence continue to be displayed, but player controls are disabled and no sounds are produced. Car motion continues, however, and interactions with obstacles and with the opponent car are unaffected. But no additional score points will be added and the scores will not be reset until a new play sequence is initiated. If at least one credit remains in the credit accumulator, then the ONE PLAY START push button will light up; if two or more credits remain, then the TWO PLAYER START push button will light up also.

3.3.4 OWNER/OPERATOR OPTIONS: The Crash'N Score game features three options that allow the owner/operator to structure the game play—that is, change some of the rules or alter the game time—at the game site. All three options are simple manual adjustments and are physically located on the printed circuit board inside the game cabinet.

(a) *Coin Credit Option.* The 1 credit/coin—2 credits/coin option consists of a two-position, slide switch. When the slide is put in one position, the game is structured to enter one credit into the credit accumulator each time a coin is deposited and clears either coin mechanism. When the slide is put in the other position, two credits are entered into the credit accumulator for each coin deposit. Subparagraph 4.3.1 in Section IV of this manual gives instructions for making this adjustment.

(b) *Length of Game Time Option.* This option consists of a potentiometer (Trimpot) that has a stud projecting out from the top. This stud can be moved with the finger and then left in a new position that causes the game time to increase or decrease (within the minimum and maximum limits listed in the Specifications in Section II), as desired. Subparagraph 4.3.2 gives instructions for making this adjustment.

(c) *Bonus Credit Option.* This option consists of a miniature switch assembly that has four independent, side-by-side 2-position switches. When all four switches are set in their "off" positions, no bonus credits are awarded. When one or more switches are set in the "on" position, bonus credits will be given as soon as a player's score reaches the achievement level programmed by that switch code, (for example, at 10 points, or at 20 points, etc.). Subparagraph 4.3.3 gives instructions for making this adjustment.

3.4 DETAILED TECHNICAL DESCRIPTION OF OPERATION

3.4.1 GENERAL COMMENTS: This paragraph 3.4 gives a component-level technical description of the game's electronic circuitry, and the following drawings supplement the text: drawing number 004256 (in four sheets) is a schematic diagram of the circuitry located on the printed circuit board; drawing number A004256 is an assembly diagram showing locations of components mounted on the PCB; and drawing number 004218 is a schematic of the harness wiring. These drawings, along with a schematic diagram of the TV monitor's circuitry, are included in Section VII of this manual.

On the PCB and on its schematic each integrated circuit device location is identified by a column letter designation (A thru R) and by a row number designation (1 thru 10).

On the PCB schematic the symbol "P" (which appears at various inputs to logic gates and other integrated circuits) indicates a connection to +5 volts through a pull-up resistor.

The design of the car control circuitry is virtually identical for both cars; sheet 3 of the PCB schematic covers Car I and sheet 4 covers Car II. The main differences between these two sheets are:

- (a) The signals 2 PLAYER and 2 PLAYER appear on sheet 4 (in zone C4). During a 1-player game these signals prevent Car II from appearing on the TV screen and disable Speaker 2.
- (b) The signals FREE GAME TONE and SCORE TONE appear on sheet 3 (in zone B3). They cause Speaker 1 to produce the beeping sound and the buzzing sound. Speaker 2 does not produce either of these sounds.

3.4.2 TV SYNCHRONIZATION INFORMATION (REFER TO PCB SCHEMATIC, SHEET 1 ZONES C,D 6 THROUGH 8):

The output of a 14.3-MHz crystal-controlled oscillator is passed through an inverter to produce the system CLOCK signal at A1 pin 2. This signal is applied to the horizontal countdown chain formed by the type-9316 devices in locations A2, C2 and B2. Here the frequency is divided by 908 for each video scan line on the TV screen (a horizontal sweep frequency of 15.76 KHz). In the vertical countdown, formed by the type-7493 devices in locations E1 and D1 and the type-74107 flip-flop FH1, the line rate is further divided by 263 for a video frame rate (vertical sweep frequency) of 60 Hz. This dividing-down in the countdown chains is done as follows.

The horizontal countdown chain starts at a count of 116 (binary 0001110100) and advances to a count of 1024 (binary 1111111111). The H SYNC signal (horizontal sync pulse) begins at count 256 and is 64 clock pulses wide (4.47 microseconds). H SYNC is produced at pin 9 of flip-flop B3, where the rising edge of the 256H signal clocks a low through to the flip-flop's Q

output pin. The Q output is set back to high by the 64H signal that later passes through gate A3 at pin 6.

The vertical countdown chain starts at a count of zero (binary 00000000) and advances to a count of 262 (binary 10000110), at which time a low appears at pin 12 of gate D3. This low is clocked through flip-flop B3 (with Q output at pin 5) at the next rising edge of the 512H signal. The V RESET signal then resets the vertical countdown chain to zero. The counting cycle resumes after the V RESET signal is cleared again one horizontal scan line later. The V SYNC signal (vertical sync pulse) is produced at F1 pin 10 by the R/S flip-flop formed by gate F1. The pulse begins with V RESET and is $4\frac{1}{2}$ scan lines long (290 microseconds).

The H SYNC and V SYNC signals serve as the basis for the synchronization information sent to the TV monitor on the composite video signal.

3.4.3 PLAYFIELD GENERATION (SHEET 1 ZONES B, C 5 THROUGH 8): The stationary objects appearing on the TV screen—flags, oil slicks and barriers—originate in contributions to the composite video signal derived from the PROMs (programmable read-only memories) in locations D2 and E2. Various signals coming from the horizontal and vertical countdown chains are applied to the A_0 thru A_7 address inputs to the PROM in location D2, and cause D2 to produce the set of signals OBJ 0 thru OBJ 3. These four signals are applied to the A_4 thru A_7 address inputs of PROM E2, and certain other signals from the countdown chains are applied to the A^0 thru A_3 address inputs. The four signals produced at this PROM's B_0 thru B_3 outputs are applied to a type-74153 multiplexer device that produces a serial output at F2 pin 7. After clocking with the 1H signal at flip-flop K3, the SHAPES signal is produced at K3 pin 9.

Certain combinations of the OBJ 1, OBJ2 and OBJ 3 signals are then gated with the SHAPES signal to produce the following signals: FLAGS at H3 pin 6, SLICKS at H3 pin 3, and BARRIERS at H3 pin 11. The FLAGS signal goes to the white/black flag generator circuit (see subparagraph 3.4.12), which produces the white flag and black flag contribution to the composite video signal. The SLICKS signal serves as the oil slicks' contribution to the composite video signal. The BARRIERS signal is gated at F3 pin 2 with the Q output from pin 9 of flip-flop J7. After further gating at F4 pin 6 and one inversion stage, the BARRIER VIDEO signal is produced at R3 pin 12. This signal serves as the barriers' contribution to the composite video signal.

Note that the Q output (pin 8) of flip-flop J7 is connected back to the "d" input (pin 12), forming a simple binary flip-flop. Provided the ATTRACT signal is high (meaning that the game is not in the attract mode), and that the "Q" Latch is in its "reset" state (see subparagraph 3.4.6), the output at L8 pin 10 will be high. Signals applied at J8 pin 13 can then pass through the gate and clock flip-flop J7. The signals

applied at J8 pin 13 come from the latch formed by inverter J9. This latch "debounces" the signals produced by the front panel barriers push button and that reach the PCB via edge connector pins K and 10. This circuit arrangement insures that the barriers switch is disabled both during the attract mode and while the game timer is counting down.

3.4.4 COIN VALIDATION (SHEET 2 ZONES C, D 6 THROUGH 8): Each coin mechanism has an SPDT (single-pole, double-throw) switch that is activated momentarily whenever a coin passes through the coin mechanism and on into the coin box. Drawing number 004218, the harness schematic, shows how these are wired and how they connect to the PCB edge connector. On the PCB two inverter latches (at J9 pins 10 and 12 for coin switch #1, and at C10 pins 8 and 10 for coin switch #2), debounce the coin switch signals. The outputs from each latch are applied to a dual stage of flip-flops (formed by A7 for Coin Switch #1 signals, and by A8 for Coin Switch #2 signals). These dual stages are clocked by the 64V and 64V timing signals, respectively, and any latch output signal that is at least as wide as two cycles of the clocking signal will cause the second flip-flop stage to produce a pulse (COIN #1 at A7 pin 9, and COIN #2 at A8 pin 9). These pulses are used to set the "Q" Latch (see subparagraph 3.4.6) and to drive the coin counter (see subparagraph 3.4.5).

The Q outputs from each second flip-flop stage are applied to individual flip-flop latch configurations, and both configurations are clocked by the 16V timing signal. If the owner/operator has set Switch S1 (the 1 credit/coin—2 credits/coin option switch) for 1 credit/coin structuring, pins 2 and 11 of gate P2 are connected via the switch contacts to +5 volts (through resistor R2). One pulse will be produced at P2 pin 12 each time a coin passes through Coin Switch #1, and at P2 pin 8 each time a coin passes through Coin Switch #2.

If the owner/operator has set Switch S1 for 2 credits/coin structuring, however, the 4V timing signal (instead of +5 volts through resistor R2) is connected via the switch contacts to pins 2 and 11 of gate P2. With this arrangement two pulses will be produced at P2 pin 12 each time a coin passes through Coin Switch #1, and at P2 pin 8 for a coin through Coin Switch #2.

The above pulses are ORed to produce the COIN signal at gate P3 pin 8. The COIN signal is one of the two inputs that drive the credit accumulator to count up (see subparagraph 3.4.8).

3.4.5 COIN COUNTER CIRCUIT (SHEET 2 ZONES A6 AND 7): The coin counter is an electromechanical counter that is mounted on the coin assembly access door. Drawing number 004218, the harness schematic, shows how this counter is connected to the PCB edge connector. The COIN #1 and COIN #2 signals pro-

duced in the coin validation circuit (see subparagraph 3.4.4) are applied to pins 10 and 9 of gate MN1 so that a pulse is produced at MN1 pin 8 each time that a coin passes through either coin mechanism and into the coin box. This pulse passes through inverter R3 and resistor R31 to the gate terminal of an SCR, bringing the SCR into conduction. The SCR current causes the coin counter to advance by one count each time that the SCR goes into conduction.

3.4.6 "Q" LATCH (SHEET 2 ZONES D 5 AND 6): Transistors Q8 and Q9 form a discrete component latch. Note that they are complementary—Q8 is NPN and Q9 is PNP. The two stable states of this latch are:

- (a) Latch reset, with *neither* transistor conducting, meaning that the game is in the attract mode.
- (b) Latch set, with *both* transistors conducting, meaning that the game is in the play mode: game timer is counting down or else game time has elapsed but one or more credits are remaining in the credit accumulator.

The signal Q, produced at pin 10 of inverter E10, is high when transistor Q8 is conducting, and is low when Q8 is not conducting.

The "Q" Latch is set either when diode D25 is forward-biased by a COIN #1 signal pulse to low, or when diode D26 is forward-biased by a COIN #2 signal pulse to low. These two signals are produced by the coin validation circuit when players deposit coins (see subparagraph 3.4.4). Normally the "Q" Latch is reset when pin 3 of Gate B5 is low, because this low interrupts the flow of base current to transistor Q8, causing it to go out of conduction. The low at B5 pin 3 is produced when the END GAME signal is high (meaning that game time has elapsed) at the same time that the 1 or 2 CREDIT signal is high (meaning that no credits are remaining in the credit accumulator).

The "Q" Latch can also be reset should transistor Q7 go into conduction, also interrupting the base current flow to Q8. However, the antenna wire is connected directly to the base of transistor Q7 and a signal can be produced on this wire only by static discharge current flow.

3.4.7 "START" PUSH BUTTON SWITCHES (SHEET 2 ZONES A, B 6 THROUGH 8): The harness schematic drawing number 004218, shows how these switches are wired and how they connect to the PCB edge connector. Anytime that a player depresses either push button, ground is connected through the switch's contacts to the input of an inverter (at J9 pin 3 via edge connector pin 8 for the ONE PLAYER START push button, and at J9 pin 1 via edge connector pin 7 for the TWO PLAYER START. Each inverter output connects to the "D" input of a flip-flop (at K4 pin 12 for the ONE PLAYER START and at K4 pin 2 for the

TWO PLAYER START). The 64V timing signal is applied to the "clock" inputs of each flip-flop. However, the signal applied at the "D" input of the flip-flop will be ignored if a low is being applied at the flip-flop's "Clear" input (K4 pin 13 and K4 pin 1).

With the gating arrangement at L4 pins 12 and 11, a player depressing the ONE PLAYER START push button is ignored *unless* the 1 OR 2 CREDIT signal (applied at gate L4 pin 12) is low (meaning at least one credit is remaining in the credit accumulator), at the same time that the ATTRACT signal (applied at Gate L4 pin 11) is also low (meaning that either the "Q" Latch is reset or the game timer is not counting). Likewise, with the gating arrangement at L4 pins 3 and 2, a player depressing the TWO PLAYER START push button is ignored *unless* the ATTRACT signal (applied at gate L4 pin 3) is low at the same time that latch MN2 (applied at gate L4 pin 2) has been set (meaning that at least two credits are remaining in the credit accumulator).

The 1 CR START signal (from pin 8 of flip-flop K4) and the 2 CR START signal (from pin 6 of flip-flop K4) are gated to produce the START signal at gate K5 pin 3. The 1 CR START and 2 CR START signals are also used to reduce the credit count in the credit accumulator (see subparagraph 3.4.8). The START signal is applied to the "D" input of the start flip-flop (at J7 pin 2). Clocking for this flip-flop is provided by ANDing the 32V timing signal with the flip-flop's Q output. Note that the flip-flop can respond to clocking only when the signal applied to the "Clear" input (J7 pin 1) is high (meaning that the "Q" Latch has been set and the game timer is not counting down).

3.4.8 CREDIT ACCUMULATOR AND LAMP DRIVERS FOR "START" PUSH BUTTONS (SHEET 2 ONES C, D 2 THROUGH 4): The type-74193 device in location P4 serves as a binary up/down counter that operates between count 0 and count 15. Clock pulses applied at P4 pin 5 will cause the counter to count up; the "up" pulses are produced at Gate N4 pin 1 by ORing the COIN signal (coming from the coin validation circuit, see subparagraph 3.4.4) with the BONUS COIN signal (coming from the bonus credit circuit, see subparagraph 3.4.11). Clock pulses applied at P4 pin 4 will cause the counter to count down; the "down" pulses are produced at gate MN1 pin 3 by ANDing the 1 CR START signal and the signal resulting from ORing the 8V timing signal with the 2 CR START signal. With this clocking arrangement, credits are entered into the coin accumulator when coins are deposited into the game and when players earn bonus credits, and credits are removed when players depress the start switches.

The connection from P4 pin 12 to P4 pin 11 prevents the type-74193 counter from "wrapping around" to zero, should additional credits happen to be entered after count 15 has been reached.

The counter data outputs (P4 pins 3, 2, 6 and 7) are decoded to produce the 2 CREDIT signal at inverter R3 pin 2, and the 1 OR 2 CREDIT signal at gate P3 pin 3.

The 2 CREDIT signal connects via resistor R65 to the gate terminal of the SCR that drives the backlighting lamps behind the TWO PLAYER START push button. Likewise, the 1 OR 2 CREDIT signal connects via resistor R71 to the gate terminal of the SCR that drives the backlighting lamps behind the ONE PLAYER START push button.

3.4.9 GAME TIMER (SHEET 2 ZONES C5 AND 6): The type-555 device in location R10 and the type-7490 divide-by-10 decade counter in location P10 form the game timer. The type-555 device is connected as a very low frequency oscillator, but the END GAME signal (applied at R10 pin 4) prevents it from producing an output until a play sequence is initiated. The START signal applied at P10 pins 2 and 3 resets the type-7490 counter to count0 after a player depresses a lighted start push button. This count 0 pulls the END GAME signal (produced at P10 pin 11) low.

The type-555 device's output at R10 pin 3 is used to clock the type-7490 counter; each oscillation from the type-555 device causes the counter to advance by one count. When the counter reaches a count of 6, the 8FI timing signal (applied at F10 pin 11) is allowed to pass through the gating to produce the FLASH signal (at F10 pin 8). This FLASH signal connects to the score display circuit (see subparagraph 3.4.10) and causes the score numerals to blink during the last one-eighth of the game time.

When the counter reaches a count of 8, the END GAME signal is brought high and the END GAME signal (produced at inverter N10 pin 10) goes low. The END GAME at low prevents the type-555 device from producing an output. The END GAME signal is used in the start push button circuit (see subparagraph 3.4.7) as one of the conditions for clearing the attract flip-flop.

The potentiometer R4 provides the game time option. By manually adjusting this potentiometer, the owner/operator increases or decreases the type-555 device's oscillation frequency, with the result that the total game time is shortened or lengthened.

3.4.10 SCORE REGISTERS AND SCORE DISPLAY (SHEET 1 ZONES D 2 THROUGH 5): The type-7490 decade counter devices in locations L1 and L2 form Car I's score register, and the type-7490 decade counter devices in M1 and M2 form Car II's score register. Both registers are reset to zero when the START signal goes high. Clocking for Car I's score register is provided at L1 pin 14 by the SA signal (coming from the Hit 1 detector, see subparagraph 3.4.12), and clocking for Car II's score register is provided at M1 pin 14 by the SB signal (coming from the Hit 2 detector).

The four most significant data bit outputs from each register—the signals 1E through 1H from Car I's register, and 2E through 2H from Car II's register—are connected to the bonus credit circuit (see subparagraph 3.4.11). All 16 data outputs from the score

registers—the signals 1A through 1H and 2A through 2H—are connected to two type-74153 multiplexer devices in locations K1 and K2. The timing signals 32H and 256H are applied to the multiplexer address inputs (K1 and K2 pins 14 and 2).

The four multiplexer outputs are applied to a type-7448 BCD-to-7-segment decoder device in location J1, and the FLASH signal is applied at the blanking input (J1 pin 4). With this arrangement, the score numerals appearing on the TV screen are made to blink when the FLASH signal changes back and forth from low to high at a very slow rate.

The 7-segment decoder's outputs—the signals a through g—are applied to a pair of type-9312 devices in locations J2 and H1. Various timing signals from the horizontal and vertical countdown chains are also applied to these devices, and their two outputs (at J2 pin 15 and H1 pin 15) are ORed to produce a serialized score signal (at Gate H2 pin 13). After synchronization with the 1H timing signal in flip-flop K3 and gating with the 256H signal, the WHITE SCORE signal is separated out at gate H2 pin 4 and the BLACK SCORE signal is separated out at H3 pin 8. Note that when the SCORE WINDOW signal, applied at the "Clear" input of the flip-flop (K3 pin 4) is low, the serialized score signal will not be clocked through the flip-flop. The SCORE WINDOW signal is produced at gate F1 pin 1 by decoding various timing signals coming from the horizontal and vertical countdown chains.

The WHITE SCORE and BLACK SCORE signals serve as the score contribution to the composite video signal sent to the TV monitor (see subparagraph 3.4.19).

3.4.11 BONUS CREDIT CIRCUITRY (SHEET 2 ZONES A, B 3 THROUGH 5): The type-7486 exclusive-OR gates in location L3 pair up the four most significant data bit outputs from Car I's score register (the signals 1E, 1F, 1G and 1H), with the corresponding four switch contacts from S2, the bonus credit option switch. When the state set up by a switch—either a low produced by connecting ground through the switch contacts, or else a high produced by +5 volts coupled through a resistor—matches the state of the respective score register output, the exclusive OR gate will produce a low at its output. For example, when input pin 4 of gate L3 is connected to ground because switch A_x is closed, a low will be produced at output L3 pin 6 only if the 1E signal is also low. Conversely, when a high is applied through R128 to the input pin 4 of gate L3 because switch A_x is open, a low will be produced at output L3 pin 6 only if the 1E signal is also high.

If the score in Car I's score register reaches the achievement level set up in switch S2, then a signal is produced at gate N3 pin 8 that sets latch N2 at pin 1. The latch output at N2 pin 4 goes high and clocks the type-74107 J/K flip-flop at P1 pin 12, causing the flip-flop's Q output (at P1 pin 2) to go low. When the H RESET signal (applied at the "clear" input, P1 pin 13)

goes low, the Q output is forced back high. This change of state from high to low to high again produces a pulse at the output of gate P3, pin 6, the BONUS COIN signal. This signal causes the credit accumulator to count up by one count (see subparagraph 3.4.8).

The design for sensing the Car II score is identical to that for Car I. The type-7486 exclusive OR gates in location M3 pair up the four most significant data bit outputs from Car II's score register (the signals 2E, 2F, 2G and 2H), with the corresponding four switch contacts from S2. If the Car II score reaches the achievement level, then a signal is produced at gate N3 pin 6 that sets latch N2 at pin 10. The latch output at N2 pin 9 goes high and clocks flip-flop P1 at pin 9, causing P1 pin 6 to go low. When H RESET goes low, P1 pin 6 is forced back high. This change of state produces a BONUS COIN pulse.

The BONUS COIN signal also connects to pin 12 of the type-9602 retriggerable multivibrator (one-shot) in location R1. A pulse transition at pin 12 causes the device to produce an output pulse whose width is determined by the R-C combination R1 and C4. After gating with the 4V timing signal, the FREE GAME TONE signal is produced at gate MN1 pin 6. This signal is the beeping sound contribution to the sound summing circuit (see subparagraph 3.4.23).

3.4.12 WHITE/BLACK FLAG GENERATOR, HIT DETECTORS AND SCORING SIGNAL CIRCUIT (SHEET 1 ZONES C, D 3 THROUGH 5):

(a) *White/Black Flag Generator.* The type-7493 binary counter in location A4 and the type-7485 4-bit magnitude comparator in location B4 form the circuit that selects which of the flags on the TV screen is to be lighted (that is, to blink). When the type-555 one-shot C1, Q output pin 3, applied at the pin 9 input of gate E4 is low, the CLOCK signal (applied at E4 pin 10) is blocked and a steady high is produced at E4 pin 8. This steady high is applied at A4 pin 14, insuring that counter A4 will not change state while HIT is low.

In the type-7485 comparator B4 the counter's four output signals are compared with the four 128H, 256H, 64V and 128V signals from the countdown chains (see subparagraph 3.4.2). The signal produced at the comparator's output at B4 pin 6 goes high whenever the four pairs of signals applied to the comparator are all equal. The gating of the comparator's output signal with the FLAGS signal produces the WHITE FLAG signal at gate A3 pin 11; gating with the FLAGS signal produces the BLACK FLAGS signal at gate N4 pin 13. The FLAGS and BLACK FLAGS signals come from the playfield generation circuit: see subparagraph 3.4.3.

(b) *Hit Detectors.* If Car I drives through the lighted blinking flag, a signal is produced at gate J4 pin 6 that triggers the type-9602 retriggerable multivibrator (one-shot) in location H4, causing it to produce the HIT 1 signal at H4 pin 6 and HIT 1 at H4

pin 7, for the duration of the multivibrator output pulse. Likewise, if Car II drives through the lighted flag a signal is produced at J4 pin 8 that triggers the second multivibrator in location H4, causing it to produce the HIT 2 signal at H4 pin 10 and HIT 2 at H4 pin 9, for the duration of the multivibrator output pulse.

The HIT 1 and HIT 2 signals are applied to the inputs of exclusive OR gate D4 and the HIT signal is produced at D4 pin 6. The HIT signal goes to high whenever either multivibrator is triggered by a car driving through a lighted flag (see above paragraph). The HIT signal going high clocks device DE1. Q is a negative-going pulse with a dual function: 1) a lead pulse for score counter E3, and 2) a trigger for the type-555 one-shot C1. The one-shot C1 signal at high allows the MFI signal to pass through gate E4 and drive counter A4 at pin 14, causing the counter to count at the MFI rate until the multivibrator pulse time elapses. This counting interval leaves counter A4 at some new, randomized state, causing some random flag on the TV screen to light up.

(c) *Scoring Signal Circuit.* The type-74192 decade-up/down counter device in location E3 provides the means for generating a series of score pulses that correspond to the numeral showing in the lighted flag. For example, if a car drives through a lighted flag having a numeral 5, this counter clocked at 211's rate will produce a series of five pulses at its output at E3 pin 3. The counter's output signal is gated with a signal produced at E4 pin 11, where the 1FI signal (applied at E4 pin 12) is gated with the product of ANDing GT₁ and GT₂ from the game timer (see subparagraph 3.4.9). The GT₁ and GT₂ signals are both high only during the last one-eighth of the game time. This means that the 1FI signal (which originates in Car I's frame counter, see subparagraph 3.4.13), passes through gate E4 only during the last one-eighth of the game time. The result of the gating at F3 pins 11 and 12 is that the signal produced at F3 pin 11 will represent normal (undoubled) score points during the first seven-eighths of the game time, and doubled points during the last one-eighth of the game time.

This signal produced at F3 pin 11 is ANDed with the 8V signal to produce the SCORE TONE signal at E3 pin 8) that serves as the buzzing sound contribution to the sound produced by Speaker 1. The signal produced at F3 pin 11 also is gated with HIT 1 to produce the SA signal (at E4 pin 3) that clocks Car I's score register, and with the HIT 2 signal to produce the SB signal (at E4 pin 6) that clocks Car II's score register (see subparagraph 3.4.10).

When the ATTRACT signal, applied at Counter E3's "up count" clock input (E3 pin 5), is held low, the counter is prevented from counting. This means that no points can be scored during the attract mode, even if a car should happen to drive through a lighted flag. When ATTRACT is high, the counter is free to respond to the signal applied at the "down count" clock input

(E3 pin 4). The "D" input (pin 12) of flip-flop DE1 is tied to +5 volts through a resistor. When a car drives through a lighted flag, the HIT signal (applied at the clock input (pin 11) of flip-flop DE1) goes from low to high, causing a low to appear at the "Q" output (DE1 pin 8). This low is applied to pin 11 of Counter E3 and causes it to preset to an initial counter state set up by the GND, OBJ 0, OBJ 1 and OBJ 2 signals applied at E3 pins 15, 11, 10 and 9, respectively. The Counter E3 then counts down, at a rate determined by the 4FI signal (applied at E3 pin 4), until counter state 0 is reached, at which time a low is produced at the counter's "borrow" output (E3 pin 13). The borrow signal is tied back to gate F3 pin 5, and when low it blocks the 4FI clocking signal. Also, the borrow signal is passed through inverter J3, to reset flip-flop DE1 via the "clear" input (DE1 pin 13). With this circuit design the number of pulses produced at E3 pin 3 while the counter is counting down corresponds to the numeral in the lighted flag.

3.4.13 GAS PEDAL SIGNALS AND PROCESSING OF ACCELERATION SIGNALS (SHEET 3 ZONES B, C 6 THROUGH 8 FOR CAR I; SAME ZONES ON SHEET 4 FOR CAR II):

(a) *Gas Pedal Signals.* A SPDT switch is mounted on each gas pedal. The harness schematic, drawing number 004218, shows how these switches are wired and how they connect to the PCB edge connector at pin U for Car I's gas pedal and at pin 17 for Car II's gas pedal. When a player depresses the gas pedal, the respective edge connector pin is connected to ground through the switch contacts.

(b) *Processing of Acceleration Signals.* The following description applies to Car I; the design for Car II is identical. The type-74193 up/down binary counter device in location E9, together with gate C9 and flip-flop C7 ("Q" output at pin 3), form the acceleration counter for Car I. The count-up signal consists of the acceleration pulses produced at gate F10 pin 12, and the count-down signal consists of the deceleration pulses produced at gate C9 pin 3. The acceleration counter's outputs are the signals SPEED 11, SPEED 21, SPEED 31 and SPEED 41 (produced at E9 pins 3, 26 and 7, respectively), and SPEED 51 (produced at C7 pin 3). These five signals are called the speed code. The STOP 1 signal produced at gate C9 pin 6 goes high if the counter is at speed 0, if in the attract mode, or after Car I has run into an unlighted flag or a barrier (CRASH 1 signal is low). The STOP signal at high resets the counter outputs to zero.

The type-7493 binary counter device in location D8 and flip-flop C7 ("Q" output at pin 5) form a frame counter. The type-7485 4-bit magnitude comparator device in location D9 and gate C9 (with output at pin 11) form an acceleration comparator that compares the speed code—the five signals SPEED 11 through SPEED 51—against the frame count bits—the five signals 1F1 through 16F1. The result of this comparison is the GOI signal produced at D9 pin 5.

When the gas pedal is depressed the car will accelerate at the rate of one unit per 8 frames; when it is not depressed the car will decelerate at the same rate. The acceleration counter E9 counts these acceleration units. At speed 30 (counter binary output 11110), a signal produced at gate E8 pin 6 blocks out further acceleration pulses and the car will attain a maximum speed. Figure 3-3 shows the time relationship between the frame counter's output signals (1F through 16F) and waveforms of the GOI signal at all speeds from 0 (stop) through 30 (full speed).

FRAME SIGNALS

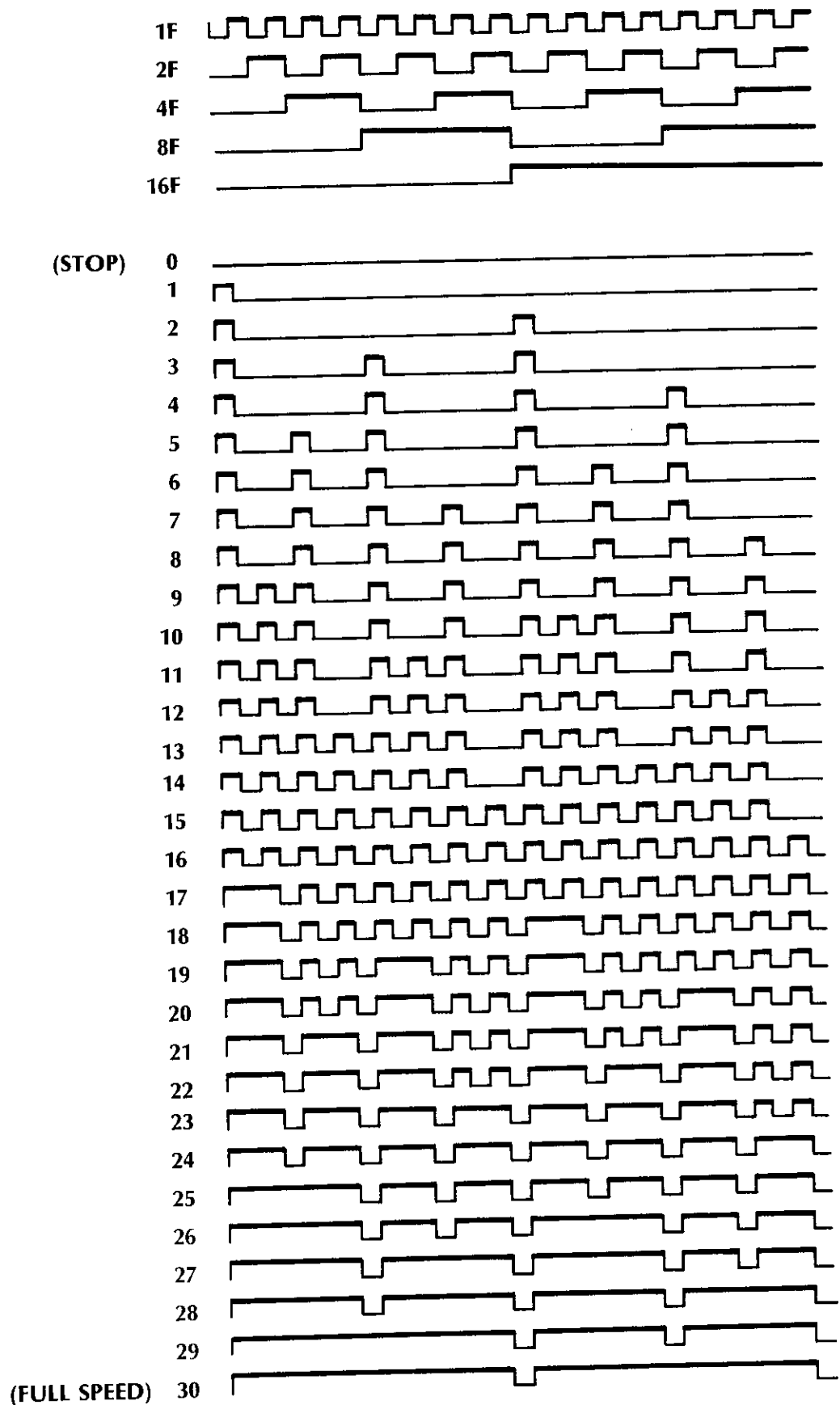

Figure 3-3 Frame Counter Output Signals and Waveforms for GOI Signal

3.4.14 CAR STEERING SIGNALS AND STEERING PROCESSORS (SHEET 3 ZONES C, D 6 THROUGH 8 FOR CAR I; SAME ZONES ON SHEET 4 FOR CAR II):

(a) *Steering Signals.* These signals originate on two small printed circuit boards—one for each steering wheel—that plug into the steering wheel assemblies mounted on the backside of the front panel (see item 7 on drawing number A000598-XX). The steering PCB remains stationary when a player turns a steering wheel. A slotted hub is bolted onto the end of each steering wheel shaft and the hub's teeth move through a curved gap on the steering PCB as a player turns the steering wheel. A pair of LED (light-emitting diode) light sources is positioned on one side of this gap, and directly opposite on the other side is a corresponding pair of phototransistors. Sheet 1 of drawing number A000607 shows mechanical details and the component layout on the Steering PCB.

Anytime a player rotates a steering wheel in either direction, the circuitry on that steering PCB optically senses the hub slots and teeth as light emissions to the phototransistors are alternately blocked and cleared. Each steering PCB produces a pair of signals in quadrature; these signals are sent to the main game PCB via edge connector pins S and 15 for Car I, and via pins T and 16 for Car II. The wiring connections are shown on the harness schematic, drawing number 004218. On the main PCB, steering processors—one for each car—decode each pair of quadrature signals into car rate and direction of rotation information.

(b) *Steering Processors.* The following description applies to schematic sheet 3 (for Car I). The design for Car II, shown on sheet 4, is nearly identical. The type-74193 up/down binary counter devices in locations F8 and H8 form the steering processor for Car I. The type-7474 dual flip-flop device in location H9 and gate F9 decode the two clocking signals that drive this steering processor. The VTC I signal and its complement VTC I serve as maximum turning rate signals. When Car I goes into a skid—either because it ran into an oil slick or into Car II—the signal produced at gate F9 pin 8 forces the car to be turned at the maximum turning rate for the duration of the SKID I signal. This can happen both in the attract mode and the play mode.

While the ATTRACT I signal is high, the signals coming from the steering PCB are ignored, meaning that player steering control is disabled. However, during the play sequence the ATTRACT I signal remains low, and the decoder circuit (flip-flop H9 and gate F9) can then translate the quadrature signal pair (coming from the left steering wheel) into direction and rate of turn information. The sample wave-forms shown in Figure 3-2 illustrate this translation. Diodes D13 and D14 are red LEDs that serve as visual indicators of the operation of the quadrature signal pair; these LEDs have no effect on the game and are

provided as servicing aids only.

The “right clock” signal (applied at F8 pin 5) causes the steering processor to count up, and the “left clock” (applied at F8 pin 4) causes it to count down. The type-74193 devices divide down the clock signals by 128.

The output signals ROI (at F8 pin 6), R1I (at F8 pin 7), and R2I, R3I and R4I (at H8 pins 3, 2 and 6, respectively), are the last five bits of the division by 128. These signals are called the rotation data and they form a rotation code that represents a total of 32 specific car orientations. For example, binary code 00000 represents the orientation with Car I pointing straight up. The code continues clockwise through 32 consecutive orientations up to binary 11111, which is just to the left of straight up.

The type-7475 quad latch device in location H7 serves as the skid latch, and its four outputs D1I through D4I (at H7 pins 16, 15, 10 and 9, respectively) are called the direction code. When the SKID I signal is high, the skid latch's outputs follows its inputs—the rotation code signals R1I through R4I coming from the steering processor. This direction code differs from the rotation code only when the car is in a skid.

When the SKID I signal goes low (meaning that Car I is in a skid), the skid latch's outputs are prevented from changing; instead the latch holds the most recent data from the steering processor. Therefore, during a skid the rotation code (signals R0I through R4I) tells in which direction the car is pointed, and the signal R0I plus the direction code (signals D1I through D4I) tell the direction along which the car moves while it is spinning or rotating rapidly.

Note that the connections of the CAR RESET I signal to Car I's steering processor (F8 and H8) are not the same as those of the CAR RESET II signal to Car II's steering processor (P8 and R8 on sheet 4 of schematic). This difference causes Car I and Car II to appear in opposite orientations on the TV screen at the beginning of a game play sequence.

3.4.15 MOTION CODE PROM (SHEET 3 ZONES C, D 5 AND 6 FOR CAR I; SAME ZONES ON SHEET 4 FOR CAR II):

The GOI signal—produced by processing acceleration/deceleration commands from the gas pedal (see subparagraph 3.4.13)—is applied to the “enable” input (pin 15) of the PROM in location F7. And the direction code data—the five signals ROI and D1I through D4I (see subparagraph 3.4.14)—are applied at the A₀ through A₄ address inputs of this PROM. The B₀ through B₇ PROM outputs—produced at F7 pins 1 through 9—are called the motion code data.

The PROM is enabled whenever the GOI signal is high. The motion code data then go to Car I's horizontal and vertical motion counters (see subparagraph 3.4.16). The four B₀ through B₃ signals of the

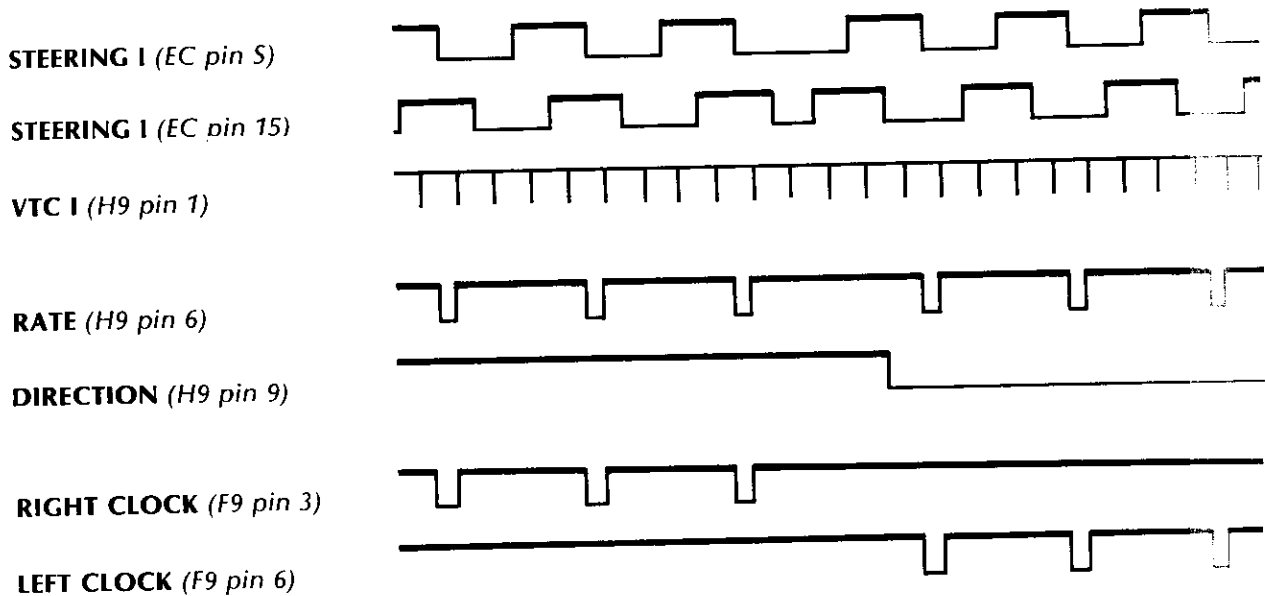

Figure 3-2 Sample Waveforms in Steering Decoder Circuit for Car I

motion code data pass through inverter stages and are applied to the "preset" inputs of the vertical motion counter's first stage (at D6 pins 3 through 6). The four B₄ through B₇ signals are gated with the V RESET I signal in gate E6, and the four gate outputs are applied to the "preset" inputs of the horizontal motion counter's first stage (at E5 pins 3 through 6).

Table 3-1 shows the data applied at the preset inputs of the horizontal and vertical motion counters for each of the 32 directions in the direction code (the five signals ROI and D11 through D41).

3.4.16 HORIZONTAL AND VERTICAL MOTION COUNTERS (SHEET 3 ZONES C, D3 THROUGH 5 FOR CAR I; SAME ZONES ON SHEET 4 FOR CAR II): The type-9316 presettable binary counter devices in locations E5, D5 and C5 form Car I's horizontal motion counter, and the type-9316 devices in locations D6 and C6 and flip-flop F5 (with "Q" output at pin 5) form its vertical motion counter. The CAR RESET I signal, produced at A6 pin 2 by inverting the CAR RESET I* signal (see subparagraph 3.4.17), resets both counters (at pin 1 of all type-9316 devices and at F5 pin 10). The CLOCK I signal, produced at A6 pin 8 (zone D6) by inverting the CLOCK signal, drives the clock inputs of all horizontal motion counter stages. The signal produced at A6 pin 4 by inverting V CLOCK drives the clock inputs of all vertical motion counter stages.

The motion counters operate on the principle of Atari's "slipping counter" method of moving objects on a raster scan display (patent number 3,793,483). Both motion counters count in parallel with the synchronization countdown chains, (see subparagraph 3.4.2). To move an object in a vertical direction on the TV screen, the vertical motion counter is forced

to count short (for upward movement) or to count long (for downward movement), with respect to horizontal countdown chain. Similarly, to move an object in a horizontal direction on the TV screen, the horizontal motion counter is forced to count short (for movement toward the left) or to count long (for movement to the right), with respect to the vertical countdown chain.

The motion counters make a unit move in the direction specified by the direction code—the signals ROI and D11 through D41—during each frame that the GOI signal is high and enables the motion counter PROM (in location F7, see subparagraph 3.4.15). The signal CLOCK I, which clocks the horizontal motion counter, is at the system clock rate of 14.3 MHz. The signal at A6 pin 4, which clocks the vertical motion counter, is two pulses per line and is gated out during vertical sync time, so that the vertical motion counter requires one less stage. This signal maintains the same amount of motion resolution in the vertical direction as in the horizontal direction.

Certain outputs from the horizontal and vertical motion counters are gated to produce the WINDOW I signal at gate B6 pin 8. The dimensions of the car window on the TV screen are 16 clock pulses wide by 8 lines high. Certain outputs from the vertical motion counter are gated to produce the VTC I signal (vertical terminal count) at B6 pin 6. This signal is used in the car steering processor circuit, (see subparagraph 3.4.14). The vertical motion counter's first stage produces the 128CVI signal at F5 pin 5; this signal drives the frame counter (see subparagraph 3.4.15).

DIRECTION CODE* D4-D1, RO	PRESENT INPUTS TO HORIZONTAL COUNTER**	PRESENT INPUTS TO VERTICAL COUNTER***
	D C B A	D C B A
00000	0100	1100
00001	0011	1100
00010	0011	1011
00011	0010	1011
00100	0001	1011
00101	0001	1010
00110	0001	1001
00111	0000	1001
01000	0000	1000
01001	0000	0111
01010	0001	0111
01011	0001	0110
01100	0001	0101
01101	0010	0101
01110	0011	0101
01111	0011	0100
10000	0100	0100
10001	0101	0100
10010	0101	0101
10011	0110	0101
10100	0111	0101
10101	0111	0110
10110	0111	0111
10111	1000	0111
11000	1000	1000
11001	1000	1001
11010	0111	1001
11011	0111	1010
11100	0111	1011
11101	0110	1011
11110	0101	1011
11111	0101	1100
STOP CODE	0100	1000

*At H7 pins 9, 10, 15, 16 and F8 pin 6 for Car I; at R7 pins 9, 10, 15, 16 and P8 pin 7 for Car II

**At E5 pins 6, 5, 4, 3 for Car I; at N5 pins 6, 5, 4, 3 for Car II

***At D6 pins 6, 5, 4, 3 for Car I; at M6 pins 6, 5, 4, 3 for Car II

Table 3-1 Unit Motion Codes Into Motion Counters

3.4.17 CAR RESET CIRCUIT (SHEET 1 ZONE B4, FOR BOTH CAR I AND CAR II): This circuit produces two signals: CAR RESET I* and CAR RESET II*. At zone B5 on sheet 3 the inverter A6 produces the CAR RESET I signal at pin 2; when low this signal resets Car I's horizontal and vertical motion counters and steering processor. Likewise, at zone B5 on sheet 4 the inverter J6 produces the CAR RESET II signal at pin 2; when low this signal resets Car II's horizontal and vertical motion counters and steering processor.

The CAR RESET I* signal is produced at the "Q" output (pin 5) of the type-7474 flip-flop in location M4. The CAR RESET II* signal is produced at gate N4 pin 10 by gating the flip-flop's "Q" output with a signal derived from certain signals from the horizontal countdown chain (see subparagraph 3.4.2).

Flip-flop M4 is under control of its clock and "D" inputs only while the START signal (applied at M4 pin 4) is high. Note that the flip-flop's "D" input (pin 2) is tied to ground; this means that only binary 0 can ever be clocked into the flip-flop each time that the 256V timing signal (applied at the clock input, M4 pin 3) changes from low to high.

While the START signal briefly goes low (after a player has depressed a lighted start push button), the flip-flop ignores the clock signal and instead is forced to change to the state with the "Q" output (M4 pin 5) at high and the "Q" output (M4 pin 6) at low. As soon as the START signal goes back to high, the flip-flop is again allowed to clock in a low (from the "D" input tied to ground) during the next low-to-high transition of the 256V signal.

This circuit design insures that the CAR RESET I* and CAR RESET II* signals briefly go high only once per play sequence, at the beginning just after a player depresses a lighted start push button.

3.4.18 CAR VIDEO PROCESSORS (SHEET 3 ZONE C2 FOR CAR I; SAME ZONE ON SHEET 4 FOR CAR II): The type-9312 device in location H5 and the 4K ROM in location F6 form the video processor for Car I. Inputs to the ROM include rotation information (the signals R01 through R41 rotation code from the steering processor, see subparagraph 3.4.14), line information (the signals L01 through L21 from the vertical motion counter), and column information (the signals C31 and C41 from the horizontal motion counter, see subparagraph 3.4.16). The ROM's eight output signals, along with additional column information (the signals C01 through C21 from the horizontal motion counter), are applied to the type-9312 device to multiplex the ROM data serially onto the complementary pair of signals produced at H5 pins 14 and 15. The CAR WINDOW I signal is applied to the "enable" input at H5 pin 10.

After clocking through flip-flop F5—to remove edge effects and to avoid race problems—the CAR I signal is produced at F5 pin 3. This signal serves as the car video contribution to the composite video

signal sent to the TV monitor.

3.4.19 VIDEO SUMMING CIRCUIT (SHEET 1 ZONE B 3 AND 4): The composite video signal is formed at the junction of resistors R23, R24, R33 and the anode of diode D12. The diode couples the synchronization information contribution produced at gate C8 pin 7 by gating the V SYNC and H SYNC signals coming from the countdown chains (see subparagraph 3.4.2). The medium white (grey) video level contribution produced at gate C4 pin 6 by gating the CAR 2 (Car II video), BLACK SCORE (Car II's score numerals), BLACK FLAGS (unlighted flags) and SLICKS (oil slicks) signals. The white (bright white) video level contribution is produced at gate P2 pin 6 by gating the BARRIER VIDEO signal, the signal obtained by combining the WHITE FLAG signal with the 8FI signal (from Car I's frame counter), and a signal derived from the CAR I and WHITE SCORE signals. Resistor R25 is included for use as a test point when servicing the game; no signal is applied at the "TEST" point during normal game operation.

3.4.20 ENGINE SOUND SYNTHESIZERS (SHEET 3 ZONES B 5 AND 6 FOR CAR I; SAME ZONES ON SHEET 4 FOR CAR II): The configuration of inverter-resistor networks connecting to the base of transistor Q10 performs a D-to-A (digital-to-analog) conversion of the SPEED 1I through SPEED 4I and the SPEED 5I signals. Transistor Q1 acts as a current source that controls the oscillation frequency of the type-555 Timer with output at D10 pin 3. The type-7492 counter devices in locations B9 and B8 divide down the frequency of D10's output signal by both 6 and 4. Signals representing various products of this division are mixed together through resistors R115 through R117; the resulting signal, MOTOR I, is the Car I engine sound contribution to the sound produced by Speaker 1.

3.4.21 CRASH AND SKID DETECTORS (SHEET 3 ZONES A 4 THROUGH 7 FOR CAR I; SAME ZONES ON SHEET 4 FOR CAR II):

(a) *Crash Detector.* As long as the signal produced at gate B5 pin 11 is high, the V RESET I signal applied at pin 3 of flip-flop A5 will clock in the steady high applied at the "D" input (pin 2) via a connection to +5 volts through a resistor. This will produce a high at the "Q" output (pin 5); the V RESET I signal will clock this high into the second "D" input (at A5 pin 12) during its subsequent low-to-high transition (at A5 pin 11). In this way both the CRASH SEQ I signal (produced at A5 pin 9), and the CRASH I signal (produced at B5 pin 8), will be kept high.

The signal produced at gate B5 pin 11 goes low whenever Car I drives into an unlighted flag or barrier. This low, applied to flip-flop A5's Clear input (pin 1), causes the flip-flop to change to the steady low

the "Q" output (pin 6) at high and the "Q" output (pin 5) at low. The high at A5 pin 6, together with the high still remaining at A5 pin 9, causes the CRASH I signal to go low. The CRASH I signal goes back high just after the next low-to-high transition of the V RESET I signal, because that signal transition will have clocked a low into the flip-flop's "Q" output at A5 pin 9, the CRASH SEQ I signal.

The CRASH I signal at low causes the Car I motion to stop (via the connection to gate C8 pins 11 and 12, zone C6), and also causes the crunch sound to be produced (via the connection to resistor R97 and diode D24). This arrangement keeps the CRASH SEQ I signal low, preventing further crashes, until Car I no longer is in contact with the unlighted flag or barrier.

(b) *Skid Detector*. If the CAR I signal is high at the same time that the CRASH SEQ I signal is low (meaning that Car I has not crashed), then the SKID I* signal going high will bring gate B6 pin 12 low. This causes the type-555 timer device in location B7 to produce a one-half-second pulse at its output pin 3, the SKID I signal. The complement of this signal—SKID I—connects to the Car I skid latch at H7 pins 4 and 13 (zone C6) and prevents the latch from accepting new data from the Car I steering processor (see subparagraph 3.4.14). The SKID I signal also causes the "tire screech" sound to be produced (via the connection to pin 13 of inverter L10 in zone B4)

3.4.22 SCREECH AND CRUNCH SOUND SYNTHESIZERS (SHEET 3 ZONES A, B 3 AND 4 FOR CAR I; SAME ZONES ON SHEET 4 FOR CAR II):

(a) *Noise Generator*. Transistor Q2 is an NPN specially selected for noise characteristics. The noise developed at its emitter is amplified by the LM324 (output at pin 1) in location C11.

(b) *Screech Sound Synthesizer*. The LM324 operational amplifier (with output at pin 14) in location C11 is configured as a free-running multivibrator that is perturbed—via coupling through capacitor C51 and resistor R106—by the noise originating from transistor Q2. This noise imparts a "gritty" quality to the signal. The SKID I signal applied at pin 13 of inverter L10 turns the amplifier on and off via the connection to C11 pin 13. The resulting signal that is coupled through R125 represents the Car "tire screech" contribution to the sound produced by Speaker 1.

(c) *Crunch Sound Synthesizer*. When the CRASH I signal—applied at the junction of resistor R97 and the cathode of diode D24—goes low, the discrete one-shot formed by transistor Q3 and the LM324 amplifier (with output at C11 pin 7) is triggered. Noise is imparted via resistor R100 and the resulting signal coupled through resistor R110 represents the Car I "crunch" contribution to the sound produced by Speaker 1.

3.4.23 SOUND SUMMING CIRCUITS (SHEET 3 ZONES B 2 AND 3 FOR SPEAKER 1; SAME ZONES ON SHEET 4 FOR SPEAKER 2):

(a) *Speaker 1*. The junction of resistors R110 and R122 through R125 forms the sound summing point where the following five analog signals are mixed:

- (1) Car I's engine sound—the MOTOR I signal—coupled through R122: see subparagraph 3.4.20.
- (2) The "crunch" signal coupled through R110 whenever Car I drives into an unlighted flag or a barrier: see subparagraph 3.4.20 (a).
- (3) The "tire screech" signal coupled through R125 whenever Car I goes into a skid: see subparagraph 3.4.20 (b).
- (4) The "beeping" signal—FREE GAME TONE—coupled through R123 whenever *either* car's score reaches the preselected score achievement level: see subparagraph 3.4.11.
- (5) The "buzzing" signal—SCORE TONE—coupled through R124 whenever *either* car drives through a lighted flag: see subparagraph 3.4.12 (c).

The analog signal developed at this summing point is coupled by capacitor C62 to the Speaker 1 audio amplifier stage formed by the LM324 with output at C11 pin 8. The potentiometer R109 provides the volume adjustment for the sound produced by Speaker 1.

(b) *Speaker 2*. The junction of resistors R56, R58 and R63 forms the sound summing point where the analog sound signal for Speaker 2 is developed. Note that only *three* analog signal contributions are mixed here: Car II's engine sound (MOTOR II), the "crunch" signal for Car II and the "tire screech" signal for Car II. The potentiometer R57 provides the volume adjustment for the sound produced by Speaker 2.

3.4.24 SPEAKER DRIVER STAGES (SHEET 3 ZONES B 1 AND 2 FOR SPEAKER 1; SAME ZONES ON SHEET 4 FOR SPEAKER 2):

The LM380 amplifier in location B10 serves as the output driver stage for Speaker 1 (via edge connector pin V). Resistor R105 couples the audio amplifier's output to the driver stage via capacitor C54. The ATTRACT signal applied at pin 11 of inverter L10 insures that Speaker 1 does not produce any sound during the attract mode.

Likewise, the LM380 in location K10 serves as the output driver stage for Speaker 2 (via edge connector pin L). Resistor R46 couples the audio amplifier's output to the driver stage via capacitor C14. The signal produced by inverter L10 at pin 4 insures that Speaker 2 does not produce any sound either during the attract mode, or during a one-player game.

IV. Installation Instructions

4.1 UNPACKING INSTRUCTIONS

4.1.1 EXAMINATION FOR SHIPPING DAMAGE:

Before shipment from the factory, components and sub-assemblies of each game are carefully checked for proper operation. However, during shipment some adjustments may have changed or parts may have been damaged. Upon initial removal of the game from the shipping container, first examine the exterior of the cabinet. Then open the rear panel access door and also examine the interior. Any shipping damage such as a dented, cracked or broken cabinet, sub-assemblies broken loose, etc., should be reported immediately to the shipper and to Atari, Inc.

Be sure to confirm that both steering wheels turn smoothly, both in the clockwise and counterclockwise directions. There are no limit stops; the wheels are free to turn continuously in either direction. Also operate both gas pedals and confirm that their movement is smooth, and that the return springs force the pedals back to their initial positions.

4.1.2 MECHANICAL INSPECTION: After determining that the game has been received in good condition, carefully inspect the interior parts and verify the following:

- (a) All slip-on and plug-in connectors are firmly seated (particularly the PCB edge connector).
- (b) The fuses are all seated in their holders
- (c) No loose foreign objects are present (especially metal objects which could cause electrical short circuits)
- (d) No harness wires have become disconnected or pulled loose.

Do not go on to the remaining paragraphs in this section until the above mechanical inspection has been thoroughly performed.

4.2 ENERGIZING THE GAME

4.2.1 APPLICATION OF AC POWER: Close the rear panel access door, making sure that it is completely shut at the bottom, and remove the key from the lock. Plug the power cord into an AC outlet providing the AC power listed in the Specifications (Section II of this manual). The wall outlet must accept a three-prong plug and the receptacle must be connected to a good earth ground.

After the power cord has been plugged in, the proper response from the game is that a picture will appear on the TV screen. If there is no response at all from the game, unplug the power cord and check the AC wall outlet. A simple, safe way to check for presence of AC power at the wall outlet is to plug in an appliance known to be working properly—such as a table lamp, radio, or an electric clock. If the wall outlet passes the check, then presume that the trouble is with the game and refer to Section VI of this manual.

CAUTION: No troubleshooting steps should be attempted inside the cabinet by anyone not familiar with safety measures and repair procedures on electrical equipment.

Do not go on to the remaining paragraphs in this section until the proper response described above has been observed.

4.2.2 CHECK ON OPERATION OF INTERLOCK SWITCH:

The interlock switch is a safety switch mounted inside the cabinet, near the bottom edge of the rear panel access door. At the factory this switch is mechanically adjusted so that it will automatically transfer to its "off" position (switch contacts open) whenever the rear panel access door is opened. When the interlock switch is in its "off" position, the AC power leading to the game's power supply is interrupted. When the access door is closed, the interrupt switch is adjusted to be in the "on" position (switch contacts closed) and AC power is allowed to reach the game's power supply, meaning that the game can operate.

After application of AC power per paragraph 4.2.1 above, correct operation of the interlock switch can be checked as follows: unlock the rear panel access door and slowly open the door. The correct response is that by the time the edge of the door has moved about 2 to 3 inches away from the cabinet, the TV screen should go dark, verifying that the interlock switch has automatically transferred to "off". While opening the access door do not insert fingers inside the cabinet, and do not allow foreign objects to fall inside. If the TV screen continues to be lighted up even after the door has been opened, immediately close and lock the door, and unplug the power cord from the wall outlet. Then refer to Section VI of this manual to replace and/or adjust the interlock switch.

Do not go on to the remaining paragraphs in this section until the operation of the interlock switch has been checked and found to be correct.

4.3 GAME STRUCTURING

Before putting the game into operation at the game site, the game structuring should be defined by the owner/operator. The term "game structuring" refers to the game rules, the length of each game, and other variable features. Paragraph 3.3.4 of Section III in this manual covers the owner/operator options featured in this game and describes how they affect the game structuring.

In the Crash 'N Score game all three options are simple manual adjustments: setting the position of a slide switch; moving a stud on a potentiometer body; and setting the positions of four side-by-side 2-position switches. All these adjustments are performed on the printed circuit board inside the

game cabinet.

Before performing any adjustment, the game should be de-energized or not operating. Further, it is recommended that the power cord also be unplugged beforehand.

Unlock and open the rear panel access door; doing this should cause the interlock switch to de-energize the game, as described in paragraph 4.2.2. If the switch fails to de-energize the game, immediately close and lock the door, unplug the power cord, and refer to Section VI of this manual to adjust and/or replace the switch.

While being careful to avoid touching any parts of the body against the TV chassis components or other wiring connections inside the cabinet, find the printed circuit board and examine its surface.

4.3.1 COIN CREDIT OPTION: Find the slide switch mounted near the edge of the PCB. The switch's approximate location is shown in Figure 4-1, and its exact location is shown as S1 on drawing number A004256 in Section VII of this manual. Note the words "1 PLAY" and "2 PLAY" engraved on the PCB alongside the switch body.

First, to structure the game for 1 credit/coin, slide the stud on top of the switch all the way toward the word "1 PLAY" engraved on the PCB. To structure the game for 2 credits/coin, slide the stud all the way toward the word "2 PLAY". Then cut out the "1" or

"2" from the Instruction Plate Card (provided with this game) and using transparent tape, attach it to the inside of the silk-screened plexiglass in the appropriate area.

Second, cut out the "10" from this card and attach it with transparent tape to the blank area in the silk-screened phrase "Bonus score value doubles in last _____ seconds." The period in each game during which the player's score blinks is not variable by the operator.

After performing this adjustment, close and lock the rear panel access door and energize the game.

4.3.2 LENGTH OF GAME TIME OPTION: Find the potentiometer (Trimpot) mounted near the edge of the board, not far from the large, black heat sink. This potentiometer's approximate location is shown in Figure 4-1, and its exact location is shown as R4 on drawing number A004256 in Section VII of this manual. Note the words "GAME TIME" engraved on the PCB alongside the potentiometer body.

To shorten or lengthen the game time, move the stud on top of the potentiometer body in a direction as shown in that figure.

After performing this adjustment, close and lock the rear panel access door and energize the game.

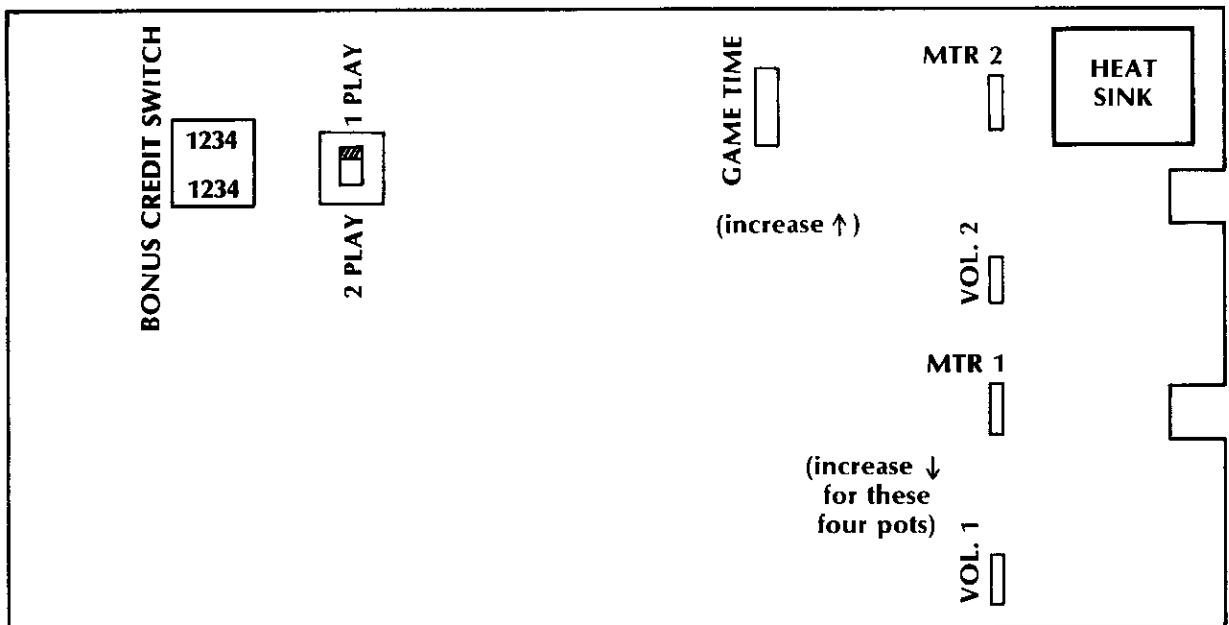

Figure 4-1 Approximate Locations of Owner/Operator Options on Crash 'N Score PCB

4.3.3 BONUS CREDIT OPTION: Find the miniature switch assembly with four side-by-side switches that is mounted near the end of the board farthest from the edge connector. The switch's approximate location is shown in Figure 4-1, and its exact location is shown as S2 on drawing number A004256 in Section VII of this manual. See also the detail below of this switch, Figure 4-2.

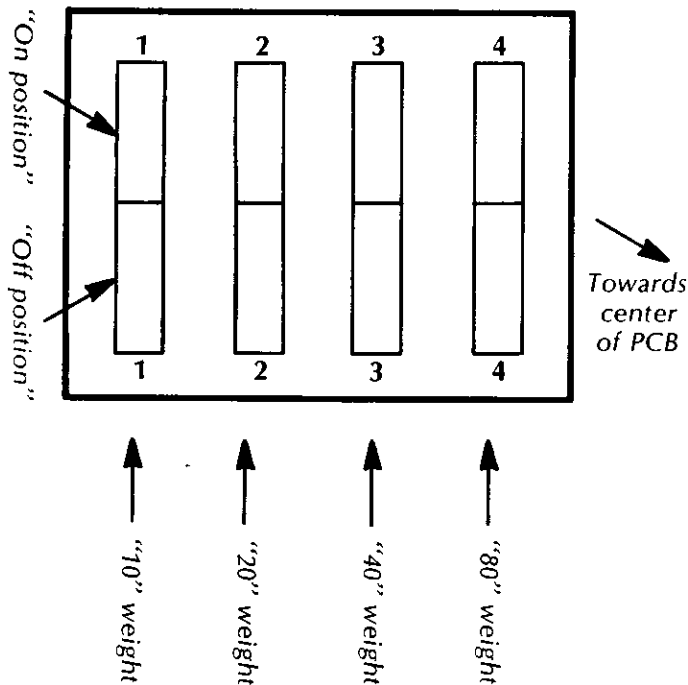

Figure 4-2 Detailed View of Bonus Credit Switch

Each of the four 2-position switches can be independently set to either an "on" or an "off" position. A weighted value of score points is assigned to each switch, namely as below:

Point value:	10	20	40	80
Lever Number:	1	2	3	4

Push forward on any of the levers, so the pointed end of the lever faces down and that lever is in the "on" position. Pushing one or more of the levers "on" will cause their respective values to be added together. We suggest total values between 40 and 90 points. For example, to set the game for extended play after 50 points, push forward on levers #1 and 3. **NOTE:** On this switch, any values set for 100 or more points means that no free game will be allowed.

After choosing the desired number of points that will initiate a bonus game, fill in the appropriate number of points on the Free Play Card also provided with this game. Place this card behind the smoked plexiglass so it rests along the retainer at the plex's bottom edge.

4.3.4 ADJUSTMENT OF SPEAKER VOLUMES AND PITCHES: Each speaker's electronic drive circuit is provided with a potentiometer (pot) that controls the volume of sounds produced by the speaker, and another controlling the pitch. These potentiometers are independent of one another and each can be adjusted manually. All four pots are found near the edge-connector end of the PCB. Their approximate locations are shown in Figure 4-1 and their exact locations are shown as R109 and R57 on drawing number A004256 in Section VII of this manual. Note the designations VOL 1 and MTR 1 (for the left speaker) and VOL 2 and MTR 2 (for the right speaker) engraved on the PCB alongside the potentiometer bodies.

To cause a speaker to produce louder or quieter sounds, move the stud on top of the potentiometers in the direction shown in Figure 4-1 for both speakers. First adjust Speaker 1's volume for the desired level of the score buzzing and bonus credit sounds; then adjust Speaker 2 so that the volume of Car 2's engine sounds match those of Car 1. Then adjust the pitch in a similar fashion with the MTR 1 and MTR 2 pots.

4.4 FUNCTIONAL CHECK OF GAME OPERATION

The following procedure provides a simple check that can be quickly performed at the game site and that does not require external test equipment. If at any point during this procedure the game's response is observed to be other than the response called for herein, assume the game is not operating correctly and refer to Section VI of this manual. If all the responses are as described here, then all major parts of the game can be assumed to be functioning correctly.

After performing the adjustments described in paragraph 4.3, Game Structuring, and in paragraph 4.2, Energizing the Game, the game should be operating in the attract mode, as per paragraph 3.3.2. The speakers should not be producing any sound. Observe the TV screen.

4.4.1 ATTRACT MODE: Just after the game is energized, near the top of the TV screen random numerals may be appearing in one or possibly in both score displays, or else both scores will be zero. Both cars should be moving across the screen. The cars should interact with any obstacles that they may encounter and also with each other. The various obstacles described in subparagraph 3.2.3 (oil slicks,

flags, and possibly barriers also) will be distributed at various locations throughout the playfield.

Look at the front panel. Neither start push button should be lighted. Confirm that all player controls are disabled by depressing both start push buttons, the barriers push button, both gas pedals, and by turning both steering wheels. None of these actions should produce any response from the game.

4.4.2 OBTAINING CREDITS: Depress the coin rejector button on the coin mechanism of each coin acceptor; make sure that each linkage is operating smoothly. Deposit a coin in one coin mechanism; no genuine coin should be rejected. If the game is structured for 1 credit/coin, upon acceptance of this first coin the game should respond by lighting up only the ONE PLAYER START push button (meaning that one credit has been entered into the credit accumulator). If the game is structured for 2 credits/coin, upon acceptance of this first coin both start push buttons should light up (meaning that two credits have been entered into the credit accumulator).

Deposit a second coin in the other coin mechanism. If the game is structured for 1 credit/coin, doing this should cause the TWO PLAYER START push button to also light up (meaning that a total of two credits have now been entered into the credit accumulator). If structuring is for 2 credits/coin, no visible response to the second coin will be evident, but a total of four credits will have been entered into the credit accumulator. If the game is structured for 1 credit/coin, deposit a third and fourth coin so that a total of four credits will have been entered into the credit accumulator.

Observe the TV screen. If barriers are present, depressing the barriers push button should cause them to disappear. Conversely, if barriers are not present, depressing the push button should cause them to appear. After confirming correct operation of this push button, make sure that the barriers are added before continuing with this procedure. Note that up to this point neither speaker should be producing any sound.

4.4.3 FIRST PLAY SEQUENCE: Depress the TWO PLAYER START push button. The game should respond as follows:

- (1) Both score displays should reset to zero.
- (2) Engine sounds should begin to be produced by each speaker. Initially both will be "idle" speed sounds.
- (3) On the TV screen the cars should change over to their initial positions: white car at left edge of screen (halfway from top to bottom, with car pointed toward center of screen), and the grey car at the right (also halfway from top to bottom, with car pointing toward the center of the screen).

(4) Both start push buttons should cease to be lighted.

(5) The barriers push button will be disabled.

Depress the gas pedal on the left side of the cabinet. The game should respond by causing the engine sound from Speaker 1 to speed up, and by causing the white car to begin to move toward the center of the playfield. While keeping the gas pedal depressed, turn the left-hand steering wheel in a clockwise direction. Doing this should cause the white car to turn to the right. Next turn the steering wheel in a counterclockwise direction; doing this should cause the white car to turn to the left. Release the gas pedal. The game should respond by causing the white car to slow down, and by causing the engine sound to also slow down. Eventually the car will come to a stop and the engine sound will return to idle.

Next perform this same check for the grey car: depress the gas pedal on the right side of the cabinet, turn the right-hand steering wheel in each direction, and release the gas pedal. Responses for the grey car should be similar to those for the white car.

For the remaining game time maneuver each car individually so that it interacts with the opponent car and with each type of obstacle at least once. The skid, crunch and scoring responses—both visual and audible—should be as described in subparagraph 3.3.3, Game Sequence in Play Mode.

After correct operation has been verified separately for each car, let the game time run out. During the last one-eighth of game time the score numerals should be blinking, and the number of points given for driving through a lighted flag should be *double* the numeral shown in the flag. When game time finally runs out, both speakers should cease to produce any sound but the cars should continue moving, starting from the positions they held at the moment the game ended. Also the final scores should remain showing.

4.4.4 GAME TIME ELAPSED, WITH CREDIT REMAINING: Confirm that the player car controls are now disabled: turning each steering wheel and depressing each gas pedal produces no response on the TV screen. But do not depress the barriers push button or either of the start push buttons.

Look at the start push buttons. Both should now be lighted, because two credits had been left in the credit accumulator when the previous game sequence ended. These two were part of the four credits entered prior to commencing that game sequence.

While observing the TV screen, depress the barriers push button. Doing this should cause the barriers to disappear.

4.4.5 SECOND PLAY SEQUENCE: Depress the ONE PLAYER START push button. The game should respond as follows:

- (1) Car 1, the white car, should change to a new position at the left edge of the TV screen, half way between the top and bottom, with the car pointing toward the center of the screen. The grey car should disappear.
- (2) The idle engine sound for Car 1 should begin to be produced by Speaker 1, but Speaker 2 will remain silent.
- (3) The score for the white car should reset to zero, and the score for the grey car should disappear.
- (4) Both start switches should cease to be lighted. One credit still remains in the credit accumulator, however.

If the game is not structured to allow awarding of bonus credits, let the game time run out. When this happens, the ONE PLAYER START push button will light up.

If the game is structured to allow awarding of bonus credits, then operate the steering wheel and gas pedal of Car 1 in order to earn points. As soon as the number of points in the white score reaches the preselected achievement level set up in the game structuring, the bonus credit beeping sound should be produced by Speaker 1. NOTE: To facilitate check-out of the bonus credit feature before depressing the start push button, it may be desirable to temporarily change the structuring to the lowest achievement level (10 points); doing this makes it easier to earn a bonus credit before the game time runs out. However, afterwards be sure to restore the structuring to the original achievement level. Refer to subparagraph 4.3.3 for the procedure for changing achievement level setting.

The bonus credit just awarded will be entered into the credit accumulator, meaning that a total of two credits are remaining. When the game time runs out, both start push buttons will then light up.

V. Maintenance and Adjustments

5.1 ROUTINE MAINTENANCE

Due to its solid-state electronic circuitry, this Atari game should require very little maintenance and only occasional adjustment

5.1.1 CLEANING: Game cabinets and glass may be cleaned with any non-abrasive household cleaner. If desired, special coin machine cleaners that leave no residue can be obtained from distributors.

5.1.2 LUBRICATION: About once every three months lightly spray the rejector linkage portion of the coin acceptor inside the coin mechanism. Use WD-40® or similar lubricant, and *avoid* spraying the entire coin acceptor.

5.2 ADJUSTMENTS ON TV MONITOR

The TV monitor need be adjusted *only* when the picture is distorted, or if contrast or brightness seem out of adjustment.

NOTE: The TV monitor is accessible only from inside the game cabinet and these adjustments have to be while the game is energized. Therefore only persons familiar with safety measures and repair procedures on electrical equipment should perform these adjustments.

The TV monitor's adjustments function like those of a conventional commercial TV set, except that the volume adjustment has no effect. The Crash 'N Score game produces its sound in a speaker separate from the TV monitor. Figure 5-1 shows the location of these adjustments on the rear of the TV monitor chassis. The following are general guidelines to follow while making these adjustments:

BRITE (Brightness)—This should be adjusted before the contrast. Adjust the brightness so that the white lines covering the screen just barely disappear when the brightness turned up.

CONT (Contrast)—Adjust so that the images are as bright as possible against the dark background without being blurred.

HORIZ HOLD (Horizontal Hold)—Adjust if the picture is slightly off-center horizontally, if the images appear warped, or if the picture is broken up into a series of diagonal lines. Adjust for a stable, centered picture.

VERT HOLD (Vertical Hold)—This needs adjustment only if the picture appears to be rolling up or down the screen. Adjust for a stable, centered picture.

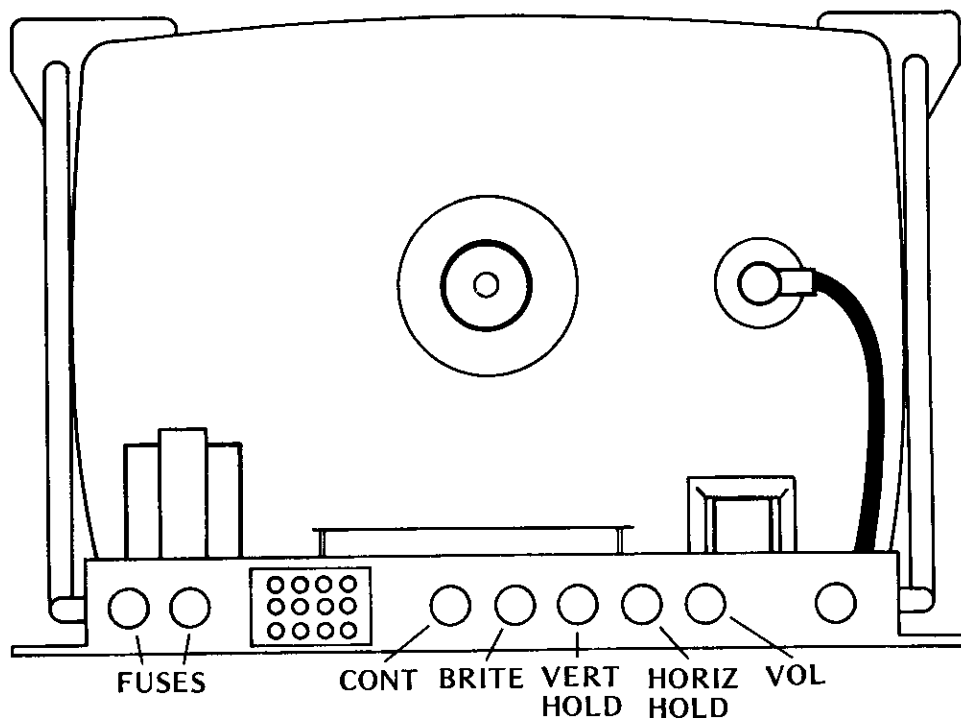

Figure 5-1 Location of Adjustments on TV Chassis

6.1 GENERAL PROCEDURE

This section describes troubleshooting procedures in detail sufficient for a person with moderate technical ability to understand. However, for those interested in gaining more information on video game technology, especially the electronics, we recommend reading the **Video Game Operator's Handbook**, manual no. TM-043. This book is available from Atari, Inc., attn. Customer Service Dept., 2175 Martin Avenue, Santa Clara, CA 95050, for \$5.00 each, or from your distributor.

6.1.1 IDENTIFYING THE TROUBLE AREA: The first troubleshooting step should be to note all observable trouble symptoms. Examples of symptoms are: depositing a coin produces no game response, no sound coming out of the speaker at any time, no picture on the TV screen. At the same time also note the game features that still work. A systematic way of checking game operation is to perform the functional check given in Section IV of this manual. Carefully train your eye to pick up all clues; by doing this an experienced troubleshooter can often spot the cause of a trouble even before he opens the cabinet.

Keeping these observations in mind, use the understanding of game operation gained from the Theory of Operation (Section III) and the schematic drawings (Section VII). Next narrow down the suspected cause of the trouble to a specific area or areas of the game: the coin mechanism, TV monitor, harness and front panel components (switches, lamps, gas pedals, brake pedals, steering wheel), electronics tray, printed circuit board, and power cord. Be careful not to overlook possible trouble areas that may seem too obvious: a power cord plug that has worked loose from the wall outlet and is no longer fully seated in the receptacle, or a rear panel access door that is not fully closed (thus causing the interrupt switch to block the AC power path to the game).

6.1.2 LOCATING THE TROUBLE CAUSE: Once a problem has been narrowed down to one or more areas, the next step is to perform various tests and measurements to isolate a specific cause of the trouble. Remember that sometimes a very complicated problem, such as erratic game operation, can be traced to a simple cause—the printed circuit board not being fully seated in its edge connector. Start with the most suspect area and trace backwards from the point where the trouble is first observable, using a process of elimination to eventually locate the faulty component, connection, etc. For example, if no sound is audible during game play, first check for a signal at the speaker leads. If no signal is present there, go back through the wiring harness connections to the printed circuit board. If there is still no signal, then systematically check back through the various components of the sound generation circuit.

Substitution of parts is a legitimate and easy way to isolate the cause. For instance, if the PCB is the suspected trouble area, remove it and substitute a known-to-be-good PCB. Then check for correct game operation. Similarly, to check the TV monitor, connect the game to a known-to-be-good monitor. The harness can often be checked by substitution also. Substitute both a known-to-be-good PCB and TV monitor. If the trouble still persists, the harness must be at fault.

While locating the trouble cause, use the technical descriptions in Section III as guides for correct circuit-level operations, and the schematic drawings of Section VII as roadmaps for tracing signal flow paths.

The test equipment for use in troubleshooting is discussed in paragraph 6.2.

6.1.3 CORRECTING THE TROUBLE CAUSE: In practice, the steps required to correct troubles can range from simple adjustments (fully seating the PCB in its edge connector, changing the setting on a potentiometer, adjusting the picture controls on the TV monitor) to repair of loose connections and replacement of defective parts. Extreme care should be exercised when removing integrated circuit devices and discrete components. Use a 40-watt soldering iron with a small tip designed especially for IC work. To remove an IC device, follow this procedure:

Remove all solder from both sides of the PCB, first melting it with the hot iron and then sucking up the molten solder with a Soldapull[®] solder sucker. After all the solder is gone, remove the IC device by gently prying up. Afterwards clean the area thoroughly, using an approved PCB cleaning solution to remove any traces of flux and dirt. Alcohol will do in a pinch, if necessary.

Insert the new IC device using an IC insertion tool, making sure that the reference notch is oriented correctly and that the device's leads are not bent during insertion into the board. Afterwards, be sure to solder each lead on both sides of the PCB, using as little solder as possible. After soldering, clean the area thoroughly to remove the flux.

Observe the same removal and insertion procedures when replacing discrete components. Trim the leads as close as possible and be sure to orient diodes and capacitors correctly.

6.1.4 VERIFYING CORRECT GAME OPERATION: After locating and correcting the cause of a trouble, re-energize the game and perform a final check on correct game operation. Doing this will verify that your troubleshooting was correct. If the game operation is still not correct, go back and double-check your work. Make sure that any replaced components were installed correctly. If this was done properly, then start the troubleshooting steps over again. Keep in mind that there may be more than one trouble at

a time, and that correcting one trouble can sometimes bring previously undetectable troubles to light.

This verification is especially important when the original trouble had been intermittent, that is, was not happening all the time.

6.2 TEST EQUIPMENT

Electronic troubleshooting of a video game essentially consists of checking for the presence of various signals and of examining their condition. A signal can be thought of as acting like a "messenger" that carries instructions from one unit or circuit to another. Many different types of signals are produced in a video game, and for this reason several unusual and perhaps unfamiliar types of test instruments are used during troubleshooting. Each instrument has its own set of advantages and disadvantages for examining a given type of signal, and both the depth of the intended troubleshooting capability and budget will determine what instruments will be needed. Some instruments are basic and essential, no matter what size of service facility, while other optional instruments are desirable because they make troubleshooting easier and quicker.

6.2.1 BASIC TEST EQUIPMENT:

(a) *The Video Probe.* This is a simple but invaluable instrument having two leads—a test-clip lead and a test-probe lead. During troubleshooting of video signals the test-clip lead is left connected to the game side of the video coupling capacitor. On the Crash 'N Score game this point is the junction of resistors R23, R24, R25 and R33 on the PCB.

When the test-probe lead is then connected to any video developmental signal, that signal will be coupled to the video signal going to the TV monitor and a video probe picture will appear on the TV screen. The shape and other characteristics of this picture will give information about the signal being probed. The video probe is suited for troubleshooting synchronization and image signals, but will not be useful for extremely fast signals (such as the clock) or for very slow analog or digital signals.

A video probe can be constructed in a few minutes from these common electrical components: a length of 20 AWG (American Wire Gauge) rubber-coated wire, a 4.7K-ohm, ¼-watt carbon resistor, and two test leads. For the leads, use a single Mouser test clip (Mouser #131C301 or 302) attached to one end of the wire, and a test prod containing the resistor on the other.

To assemble the video probe, proceed as follows: Remove the cap from the test clip and strip 3/16 inch off each end of the wire. Solder one end to the post in the test clip, thread the other end through the hole in the cap, and snap on the cap. Next unscrew the plastic body of the test prod from the point and trim both

leads of the resistor to a 3/16-inch length. Solder one resistor lead to the inside of the point. Thread the other end of the wire through the hold in the body and solder it to the other resistor lead; screw the body back onto the point.

(b) *The Logic Probe.* This is a test instrument designed for fast verification of digital IC outputs. It is small, convenient to carry, easy to read, and relatively inexpensive. The logic probe derives its power from the system under test; it has two power leads, one for connection to ground and the other to +5 volts DC. When the logic probe's tip is held against a digital signal point, three colored lamps in the tip will indicate the signal's condition or state, as follows:

- The red lamp lit indicates a high or logical level 1 (for TTL components, this is +2.4 to +5 volts)
- The white lamp lit indicates a low or logic level 0 (for TTL components, this is 0 to +0.8 volt)
- The blue lamp lit indicates that the signal is changing states
- No lamps lit indicate the grey region between 0 and 1 (for TTL this is between +0.8 and +2.4 volts)

A circuit shorted to ground will illuminate the white lamp and an open circuit will illuminate the red lamp.

The logic probe is readily available from electronic supply sources; a commercial model found satisfactory is the Kurz-Kasch model LP 520.

(c) *The Logic Pulser.* This test instrument is similar in size and shape to the logic probe, and it also derives its power from the system under test. When the logic pulser's tip is held against a digital signal point, the source and sink capabilities of the pulser override any IC output and the point is driven to the opposite logic level. If the point that the logic pulser is held against is low, pressing the switch on the side of the pulser will introduce a high pulse. Conversely, pulsing a high line will pull that line low momentarily.

During troubleshooting the logic pulser allows stimulation of in-circuit ICs with a shaped digital pulse. For example, a certain feature of the game may not be working and you suspect that a circuit is not receiving the necessary signal. Use the pulser to imitate that signal and if the circuit begins working, you have proved that the signal was in fact missing and you can begin tracking it down. This technique is very similar to jumping coils in electromechanical games such as pinball machines.

In addition to the regular "pulse" button, there is another switch mounted on the logic pulser. When this switch is set in the "rep" mode, the instrument pulses the digital signal point at a 5-Hz rate or 5 times per second. This extremely low rate is slow enough to allow watching events initiated by the pulser. Counter outputs, for example, are more easily observed when the counter is pulsed or clocked at this rate.

The logic pulser is also readily available from electronic supply sources; a commercial model found

satisfactory is the Kurz-Kasch model HL 583.

(d) *Oscilloscope.* The most versatile test instrument, and also the most expensive, is the oscilloscope. The high-speed TTL integrated circuits used in video games produce fast-rise-time signals. The oscilloscope should have a 50-MHz bandwidth, dual trace and dual time base capability. These latter features allow examination of both input and output signals simultaneously, so that precise timing relationships can be checked. The oscilloscope should also have provision for internal or external sync.

Of the newer, solid-state oscilloscopes, a satisfactory model is the Tektronix 465.

(e) *VOM or Volt-Ohmmeter.* This common measuring instrument is extremely useful in video game troubleshooting. It can be used to check line voltage, transformer secondary windings, continuity, resistance, power supply voltages, and to some extent used for measurements in the analog circuitry.

One commercial model found satisfactory is the Simpson 260.

6.2.2 OPTIONAL TEST EQUIPMENT:

(a) *The Logic Comparator.* This test instrument's main benefit is that it can be used to check the functioning of an integrated circuit device while the device is still in place on the printed circuit board. The logic comparator performs the check by comparing the suspect ICs functioning with that of an identical-type reference IC mounted in the instrument itself. Suppose that the functioning of a type-74193 device on the PCB is suspected to be defective. First insert a program card with a known-to-be-good 74193 into the logic comparator, and then clip the comparator test leads onto the leads of the suspect device. If there are any logic state differences between the reference IC and the suspect IC under test, then an LED on the logic comparator will light up to indicate which output is not functioning correctly. Once a defective IC has been located, it should be replaced.

Logic comparators are readily available from electronic supply sources.

(b) *Atari Universal Test Fixture.* In situations where a large number of video games are being serviced, investment in the Universal Test Fixture will be justified. This item of test equipment forms a test station for troubleshooting printed circuit boards after they have been removed from the game cabinet. The Universal Test Fixture has a full set of controls for operating the game and also has its own TV monitor. The game's PCB is plugged into an edge connector mounted on the side of the Fixture; with this arrangement the PCB is positioned in a convenient way for connecting probes and other test instruments.

A program card inserted into a receptacle in the top of Fixture takes the place of the game's interconnect wires. The program card thus sets up the Fixture for each particular game; the game's name is

clearly printed on the program card itself.

With the Universal Test Fixture the method of troubleshooting via substitution of known-to-be-good parts is made fast and convenient. For example, suppose that the TV picture in a game is completely broken up and you want to determine whether the game or monitor is causing the problem. Remove the PCB and plug it into the Fixture's edge connector, and also insert the correct program card for that game. If the picture on the Fixture's monitor is correct, then you know that the problem lies in the game's monitor.

6.3 SPECIFIC TROUBLESHOOTING INFORMATION

The following subparagraphs give additional troubleshooting information about certain areas of the Crash 'N Score game.

6.3.1 ANTENNA STATIC MODIFICATION: This subparagraph gives a procedure for modifying the antenna, a wire connecting via PCB edge-connector pin 18 to the base of transistor Q7. Any signal on the antenna that will bring Q7 into conduction causes the "Q" Latch (formed by transistors Q8 and Q9) to be reset. The operation of this circuit is described in detail in subparagraph 3.4.6 of this manual.

The purpose of the static modification feature is to prevent players from bringing the game into the play mode without having deposited coins into the game. Provided that the antenna wire has been adjusted to optimum length, this feature can make it impossible for a player to obtain bonus credits by inducing a static charge in the coin entrance plate or any other metal part of the game.

The antenna wire is approximately one foot long, with one end intentionally left not connected. When a static discharge occurs, an electric current is induced in this wire and an impulse is transmitted to the Q latch circuit. This impulse resets the latch, turning off game credit and changing the game over to the attract mode. To test the static modification feature, touch the end of the antenna wire with your finger; the body usually has enough capacitance to trigger the circuitry. Sensitivity of the static modification feature can be adjusted by changing the length of the antenna wire. Lengthening the wire increases sensitivity, so that a lesser charge will turn off game credit. Cutting the wire shorter decreases sensitivity, so that a larger charge is required for triggering the circuit.

If there are problems with static charges accidentally shutting off the game credit, try cutting the wire shorter in increments of ½ inch at a time. Be aware, however, that if the antenna wire is cut too short, players may be able to obtain free game credit (bonus games) by inducing a static charge in the game.

6.3.2 TV MONITOR: The TV monitor is a self-contained unit housed in its own chassis. A trouble's cause may be narrowed down to the monitor—either by the substitution method using a known-to-be-good monitor, or by verifying presence of AC power to the monitor power supply and presence of the correct composite video signal. The entire monitor can then be removed from the game cabinet. Doing this facilitates troubleshooting steps, because all monitor components will then be accessible.

A schematic diagram of the monitor circuitry is included in Section VII of this manual. After disconnecting and removing the monitor from the game, standard TV troubleshooting techniques are adequate for locating causes of trouble. Additional servicing information is available from the monitor manufacturer (Motorola).

6.3.3 COIN MECHANISM: If a player inserts a coin and the game does not respond, first check the coin mechanism. If pressing the coin rejector button forces the rejector mechanism to return the coin, then examine the coin to make sure that it is genuine. If it is, then use a set of your own test coins (which should include both very new and very old worn coins) to determine whether or not the player's coin is under-size or underweight. If your test coins are also returned, this indicates that servicing of the coin acceptor portion of the coin mechanism is called for. Generally the cause of this particular problem is an improperly adjusted magnet gate.

Inside the coin mechanism a magnet is used to test the metallic composition of the coin. Highly magnetic coins, such as those made of steel or iron, will be retained by the magnet and can be returned by actuating the wiper operating lever. Coins having comparatively high magnetic properties will be slowed down by the magnet, and will drop off the end of the rail short of the "accept" entrance and be returned. Coins having little or no magnetic properties, such as brass or zinc coins, will pass through the magnetic field so fast that they will overshoot the accept entrance and be returned.

A magnetic gate adjusted with too large a gap may pass both genuine and counterfeit coins. An adjustment with too small a gap can lead to rejection of some or even all coins. Over a period of time, the screw that adjusts the magnet gate has a tendency to work loose, resulting in a gradual narrowing of the gate. At first, only the thickest (newest) coins are rejected. As time passes, more and more coins are rejected until finally player complaints lead to the calling of the game repairman.

If pressing the coin rejector button does not cause the coin to be returned, and if the game still does not respond, then check the coin mechanism to see if the coin is jammed inside.

If you are certain that the coin is genuine, and that the coin passes through the coin mechanism and

into the cash box, then the lack of game response is probably due to some kind of electrical trouble. Check for signals at the electrical contacts of the coin mechanism before moving on to the harness and other parts of the circuitry.

VI. Schematics, Drawings and Parts Lists

<i>Number</i>	<i>Title</i>
004172	Parts List, Top Assembly
A004172	Top Assembly
004174	Parts List, Foot Pedal Assembly
004175	Parts List, Control Panel Assembly
A004175	Control Panel Assembly
003094-xxx	Parts List, Double Lite Switch Assembly
A003094-xxx	Double Lite Switch Assembly
000598-03	Parts List, Steering Wheel Assembly
A000598-xx	Steering Wheel Assembly
000607	Parts List, Steering Printed Circuit Board
A000607	Steering Printed Circuit Board
004218	Harness Schematic
004215	Parts List, Electronics Tray Assembly
A004215	Electronics Tray Assembly
004256	Printed Circuit Board Schematic
004256	Parts List, Printed Circuit Board Assembly
A004256	Printed Circuit Board Assembly



Drawn	
Checked	Mech. Eng.
Proj. Eng	Elec. Eng

Rev.	Description	Date	Apprv.	Rev.	Description	Date	Appr
A	PROD REL	9/30/75					
B	Rev per ECN 1674	10/5/75					
C	Rev per ECN 1701	10/14/75					

Item	Part Number	Qty.	DESCRIPTION
1	A004155	1	Cabinet Assembly
2	A004175	1	Control Panel Assembly
3	A004215	1	Electronics Tray Assembly
4	A004174	2	Foot Pedal Assembly
5	004214	1	Playfield Plex Screen, Clear
6	003920-02	2	Plexiglass Retainers
7	004166	1	Bottom Plex Retainer
8	004171	1	ABS Bezel, Black
9	004216-XX	1	Instruction Plate, Number Card
10	000869	2	Speaker Grill
11	000531	2	Control Panel Mntg Bracket
12	A003637	1	Coin Door Assembly
13	A004232	1	Decal Location Diagram
14	48-002	2	Speakers, 4" Motorola
15	92-007	1	23" T.V. Monitor
16	71-2114	1	Hudson Lock
17	72-6810	20	Screws, Self Tapping, #8 x 5/8 Phil Pan Hd
18	75-931	2	Wing Nuts, #10-24
19	75-5124N	10	Carriage Bolts, #10-24 x 1 1/2
20	75-010S	20	#10 Flat Washer
21	75-040	22	#10 Lock Washer
22	75-911S	20	#10-24 Hex Nuts
23	82-8116B	4	Socket Hex, Cap Screws, #10-24 x 1"
24	82-404	2	Eye Bolt, #1/2-20 x 3"
25	004212	1	R.H. Side Panel S/Screen
26	004213	1	L.H. Side Panel S/Screen
27	A004217	1	Main Harness
28	004218	Ref	Wiring Diagram
29	004177	1	Shipping Carton
30	TM-048	1	Technical Manual
31	004211	1	Plexiglas, Playfield, Smoked
32	75-915S	2	#1/2-20, Hex Nuts
33	75-015S	2	#1/2 Flat Washers
34	75-045	2	#1/2 Lock Washers
35	75-5120B	10	Carriage Bolts, #10-24 x 1 1/2
36	73-77004	8	Rivets, 3/16 x .68
37	004355	1	Free Play Card
38	72-6620	6	Screws, Self Tap, #6 x 1 1/2 Pan Hd Phil
39	A004278	1	Coin Mech Housing Harness
40	72-6616	1	Screw, Self Tap, #6 x 1" Pan Hd Phil

PARTS LIST SPECIFICATION

Page 2 of 2

Item	Part Number	Qty.	DESCRIPTION
41	A004236	1	Fluorescent Light Mounting Assembly
42	A004286-04	1	Final Assy - R.F. Shielding Enclosure
43			
44			
45	75-5132N	2	Carriage Bolts, #10-24 x 2"

8

7

6

5

D

C

B

A

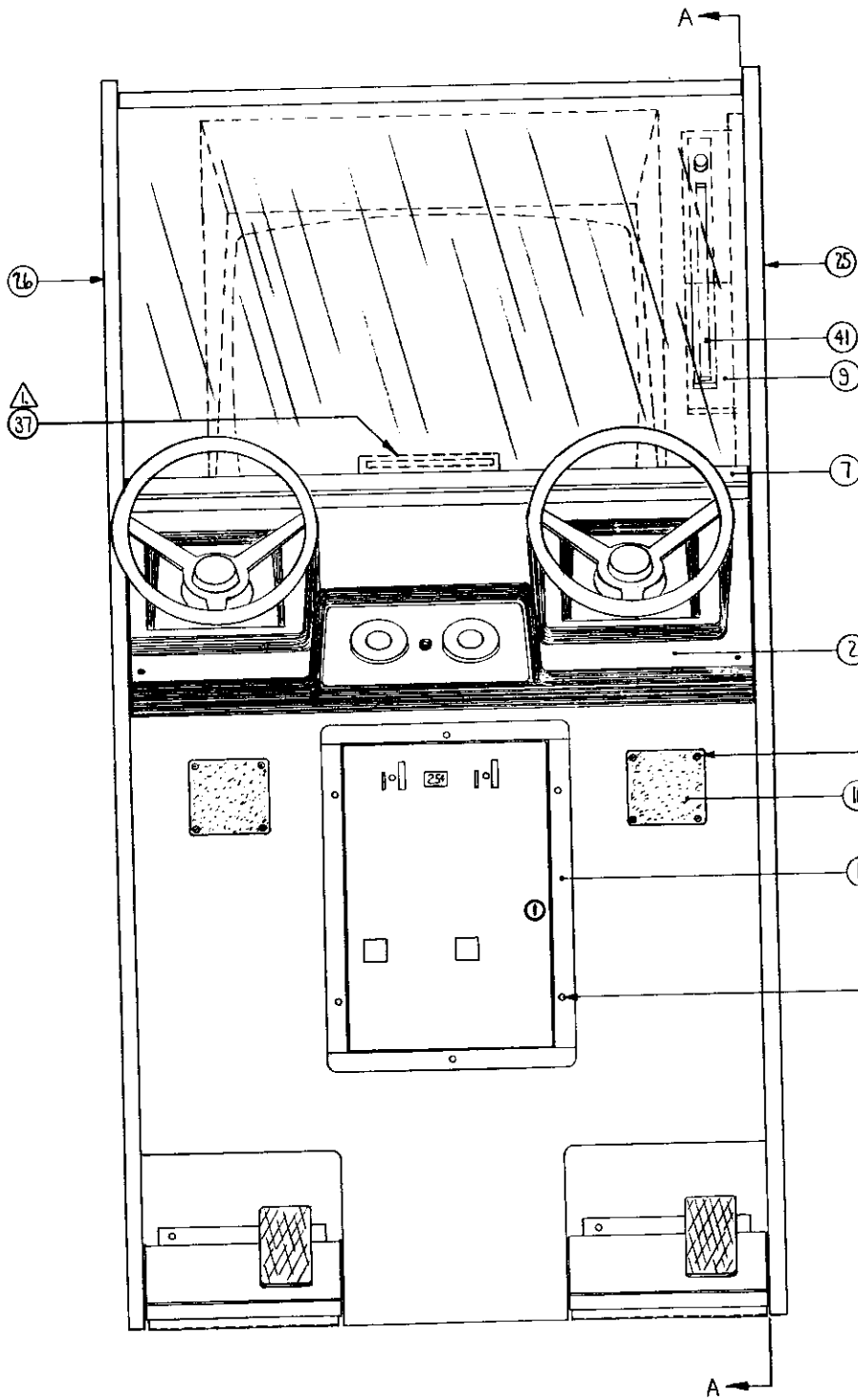

8 —

13 —

31 —

5 —

(4 EA. REQ'D) 20 21 22 35 —

6 —

17 — ✓

11 —

18 2 REQ'D

36 (8 EA. REQ'D)

14 —

17 (5 REQ'D)

35 (6 EA. REQ'D)

20

21

22

4 —

8

7

6

5

4

3

2

1

REVISIONS				
SYM	DESCRIPTION	INITIALS AND DATE		
		DRAFTG	CHECK	ENGRG
A	PROD. RELEASE	9-29-75		
B	REV. PER ECN 1674	10-3-75		
C	REV. PER ECN 1701	10-14-75		

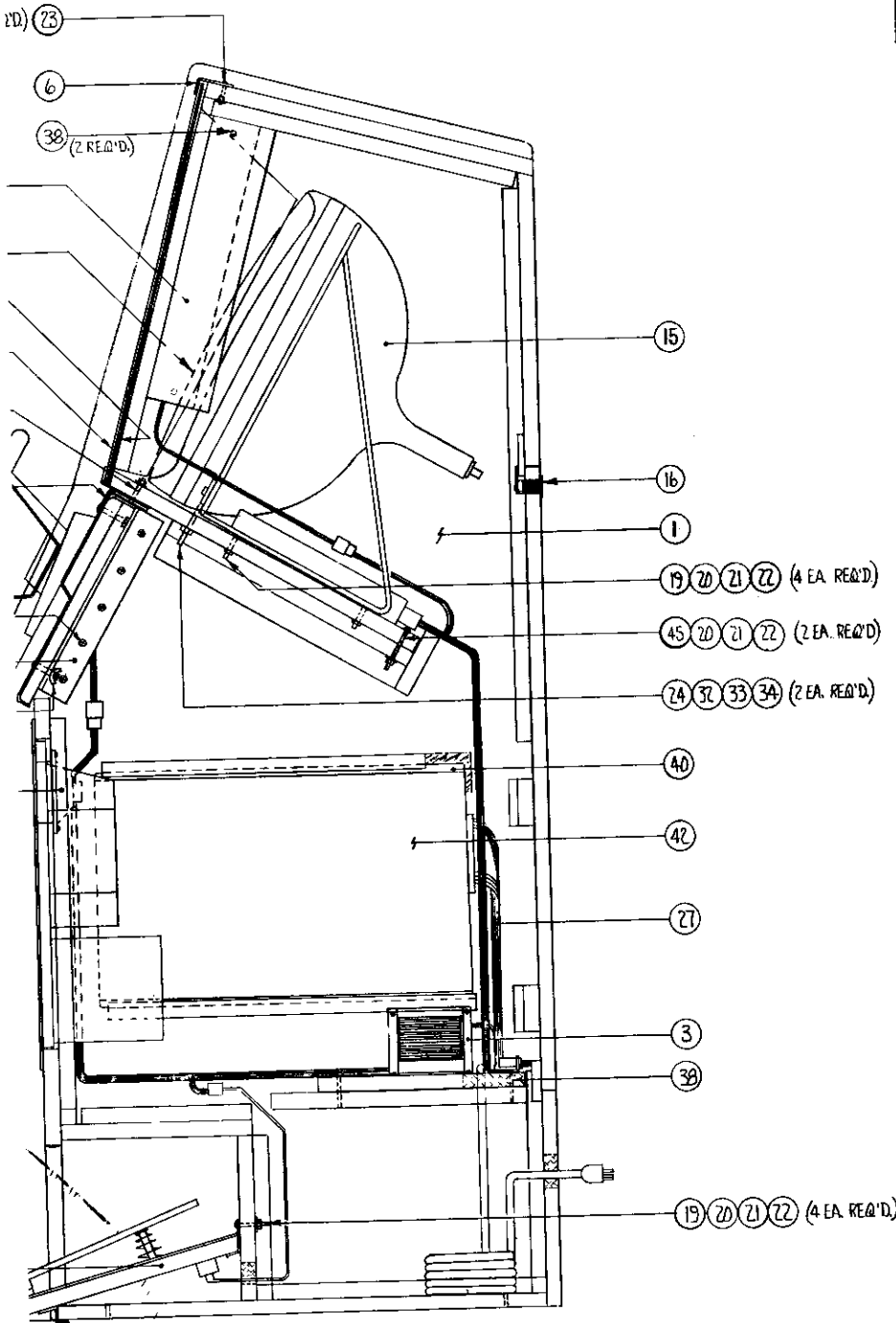

NOTES:

- 1. ITEM 37, FREE PLAY CARD TO BE INSTALLED BY OWNER BETWEEN SMOKE AND SIS PANEL.

SEC A.A.

NOTICE TO ALL PERSONS RECEIVING THIS DRAWING
 CONFIDENTIAL: Reproduction forbidden without the specific written permission of Atari Inc., Los Gatos, California. This drawing is not conditionally loaned and neither receipt nor possession thereof confers or conveys any right in, or license to use, the subject matter of the drawing or any design or technical information shown thereon. One may not in any way reproduce this drawing or any part thereof, except for manufacture by vendors for Atari Incorporated and for manufacturing under the corporation's written license. No right to reproduce this drawing is granted or the subject matter thereof unless by written agreement with or written permission from the corporation.

APPLICATION	USED ON
NEXT ASSY	

INTERPRET THIS DRAWING PER USASI Y14.5	DRAWN BY	DATE	 ATARI INCORPORATED 1400 Winchester Boulevard Los Gatos, California 95030
UNLESS OTHERWISE SPECIFIED DIMENSIONS ARE IN INCHES TOLERANCES ON:	CHECKED	8-28-75	
FRACTIONS = 1/16 .x = .1	DESIGN ENGINEER		
ANGLES = 45° .xx = .03	PROJECT ENGINEER		
SURFACE FINISH ✓ .xxx = .010	DOCUMENT CONTROL		TITLE
MATERIAL:	APPROVED		ARCADE CRASH 'N' SCORE CABINETRY - TOP ASSY
SEE P/L 004172			SIZE
			D
			DRAWING NO.
			A004172
			REV
			C
			SCALE
			SHEET 1 OF 2

4

3

2

1

D
C
B
A

DRAWING NO.
SHEET
REV

8

7

6

5

D

C

B

A

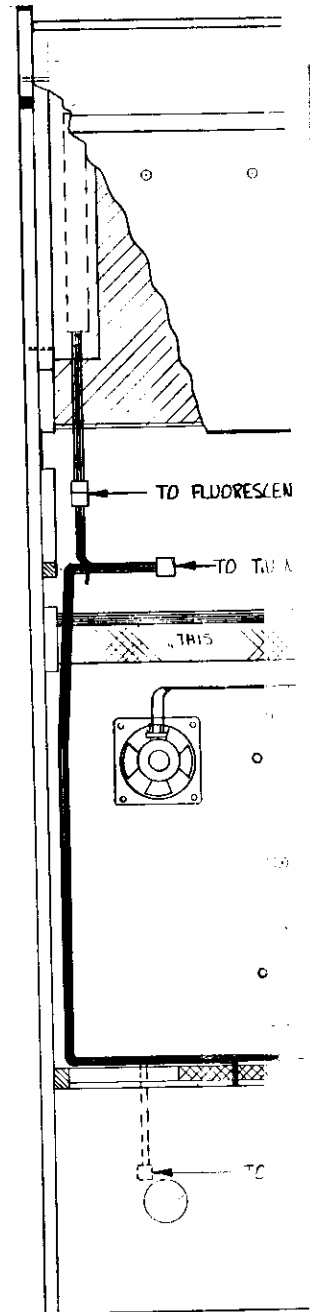
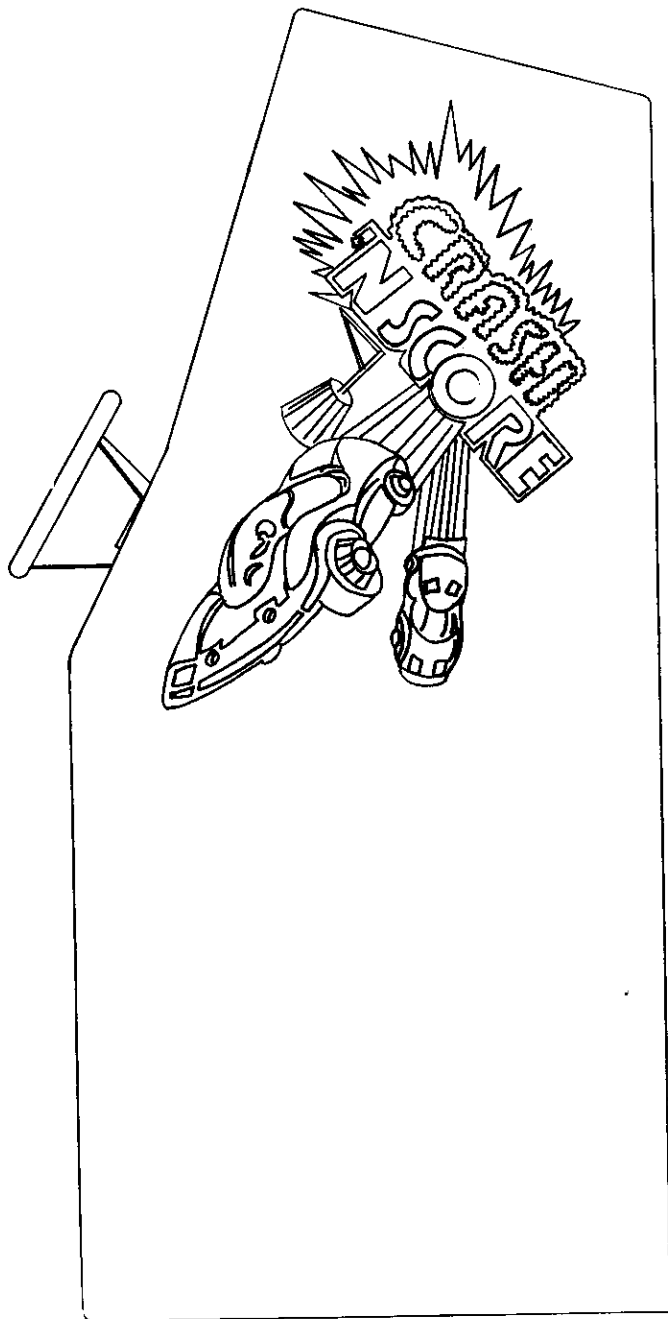

8

7

6

5

4 3 2 1

REVISIONS				
SYM	DESCRIPTION	INITIALS and DATE		
		DRAFTG	CHECK	ENGRG
	SEE SHEET 1 OF 2			

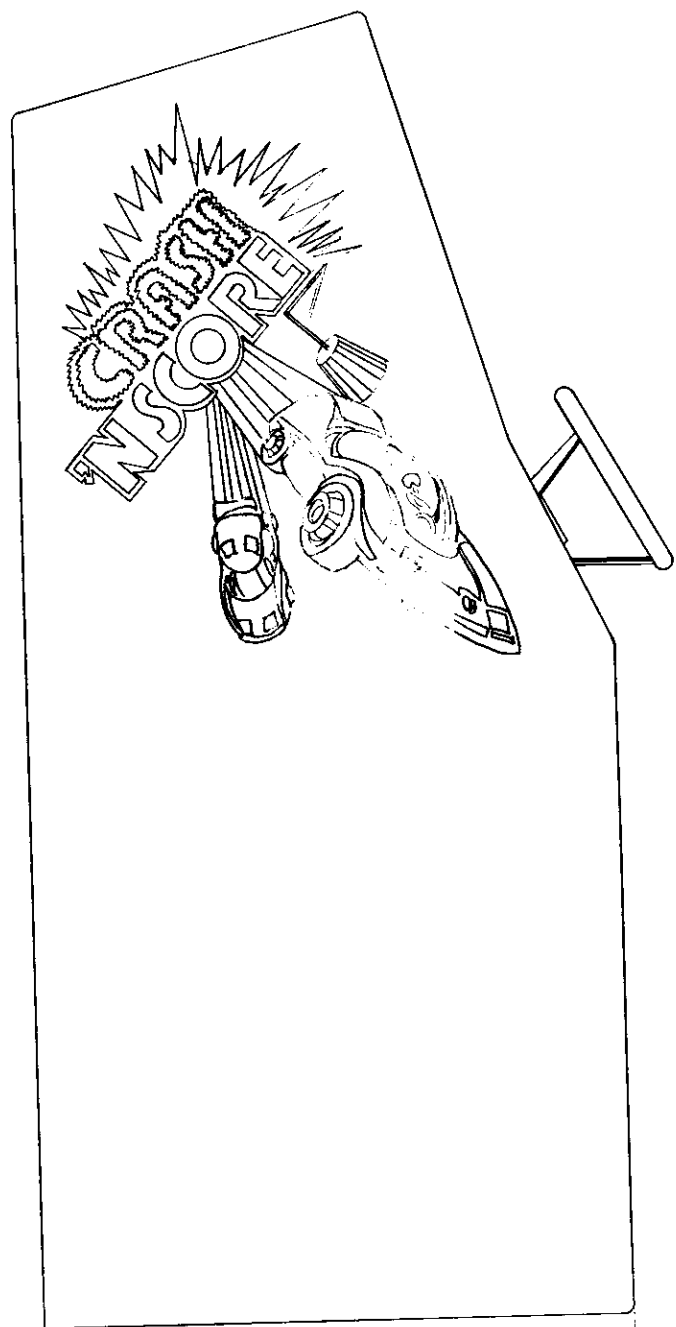
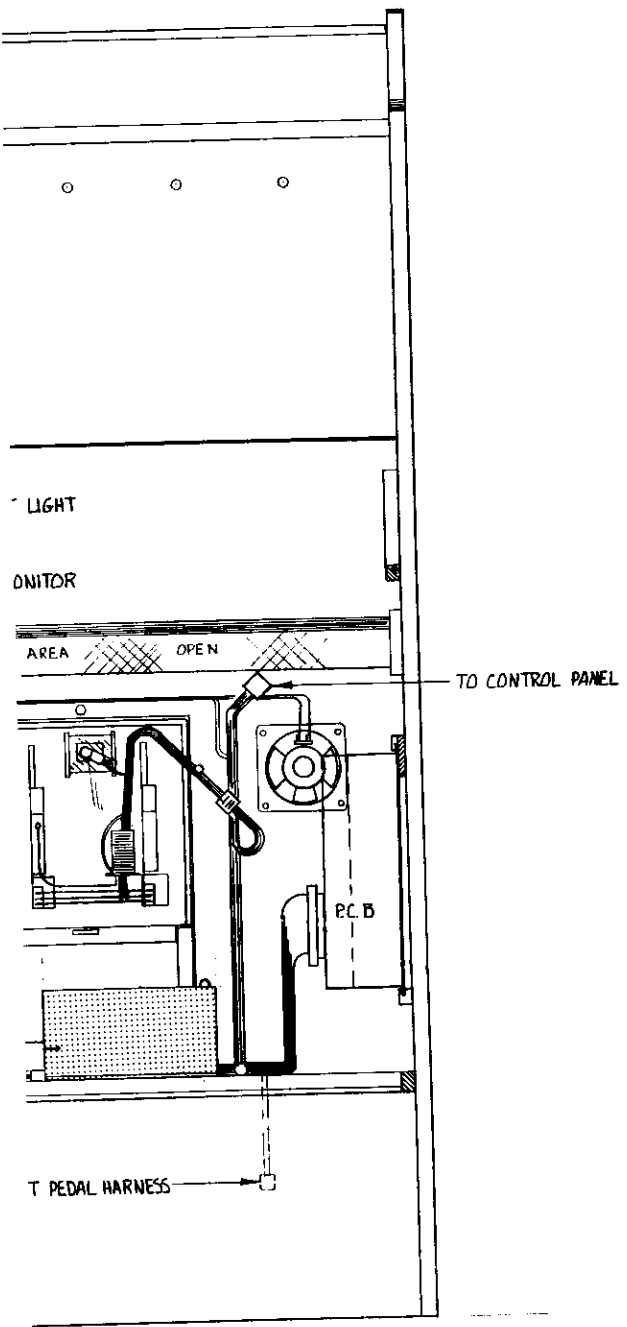

D
C
B
A

DRAWING NO.
SHEET
REV.

NOTICE TO ALL PERSONS RECEIVING THIS DRAWING
CONFIDENTIAL: Reproduction Forbidden without the specific written permission of Atari Inc., Los Gatos, California. This drawing is not conditionally issued and neither receipt nor possession thereof confers or transfers any right in, or license to use, the subject matter of the drawing or any design or technical information shown thereon, nor any right to reproduce this drawing or any part thereof, except for manufacture by or on behalf of Atari Incorporated and for manufacture under the corporation's written license. No right to reproduce this drawing is granted or the subject matter thereof waived by written agreement with or without permission from the corporation.

APPROVED	DATE
BY: [Signature]	9-29-75
APPLICATION	
NEXT ASSY	USED ON

INTERPRET THIS DRAWING PER USAS 114.5	DRAWN BY	DATE	ATARI INCORPORATED 14600 Winchester Boulevard Los Gatos, California 95030	
UNLESS OTHERWISE SPECIFIED DIMENSIONS ARE IN INCHES TOLERANCES ON:	CHECKED		TITLE	
FRACTIONS = 1/16 .X = .1	DESIGN ENGINEER		CABINET-TOP ASS'Y	
ANGLES = 45° .XX = .03	PROJECT ENGINEER		SIZE	DRAWING NO.
SURFACE FINISH ✓ XXX = A .010	DOCUMENT CONTROL		D	A004172
MATERIAL:	APPROVAL		SCALE	REV
SEE P.L. 004172				C
				SHEET 2 OF 2

4 3 2 1



ASSEMBLY TITLE / FOOT PEDAL ASSEMBLY P/L 004174

PARTS LIST SPECIFICATION		Page 1 of 1
Drawn		
Checked	Mech. Eng.	
Proj. Eng.	Elec. Eng.	REV. B

Rev.	Description	Date	Apprv.	Rev.	Description	Date	Apprv.
A		9/30/75					
B	Rev per ECN 1673	10/2/75					

Item	Part Number	Qty.	DESCRIPTION
1	A003511	1	Single Foot Pedal Assembly
2	004164	Ref	Foot Pedal Board
3	A004219-02	1	Foot Pedal Harness
4	002932	1	Front Mntg Bracket
5	002933	1	Rear Mntg Bracket
6			
7	65-071C	1	Switch, Cherry
8	002191	1	Brkt, Switch
9	72-1416S	2	Mach Screw, 4-40 x 1" Pan Hd Phil.
10	72-6810	3	Self Tapping Sheet Metal Screw, #8 x 5/8 Lg
11	72-914S	2	Hex Nut, #4
12	75-010S	4	Flat Washer, #10
13	75-040	4	Lock Washer, #10
14	75-911S	4	Hex Nut, #10-24

4

3

2

1

REVISIONS			
SYM	DESCRIPTION	INITIALS and DATE	
		DRFTG	CHECK ENGRG
A	PROD. REL.	9-30-75	
B	REV. PER ECN 1673	10-3-75	

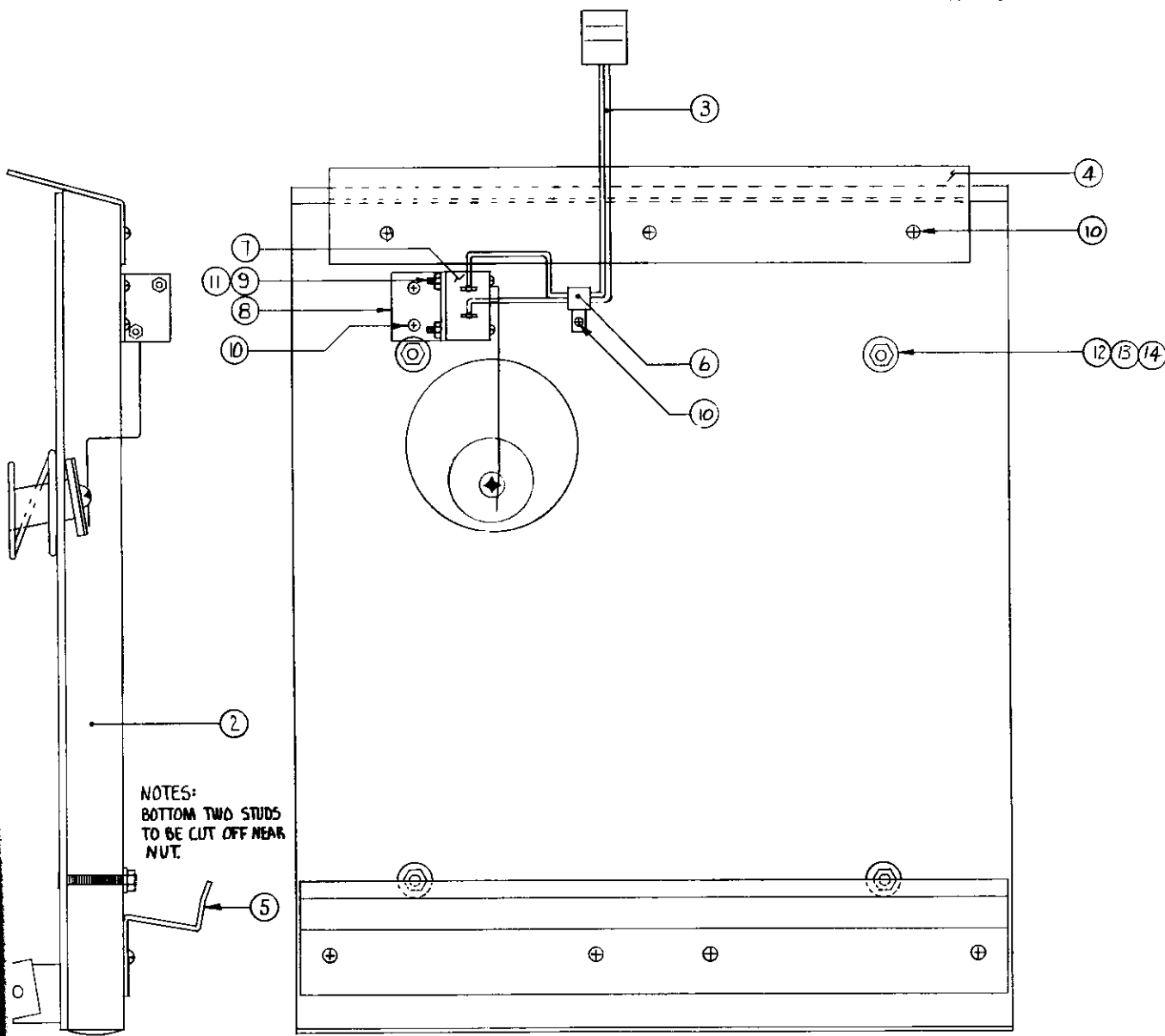

NOTES:
 BOTTOM TWO STUDS
 TO BE CUT OFF NEAR
 NUT.

D
 C
 B
 A

DRAWING NO
 SHEET
 REV

NOTICE TO ALL PERSONS RECEIVING THIS DRAWING
 CONFIDENTIAL: Reproduction forbidden without the specific written permission of Atari Inc., Los Gatos, California. This drawing is only conditionally loaned, and neither receipt nor possession thereof confers or transfers any right in, or license to use, the subject matter of the drawing or any design or technical information shown therein, nor any right to reproduce this drawing or any part thereof, except for manufacture by vendors for Atari Incorporated and for manufacturers under the corporation's written license; no right to reproduce this drawing is granted or the subject matter thereof unless by written agreement with or written permission from the corporation.

0004174	ARC. COA. W.S.CO
NEXT ASSY	USED ON
APPLICATION	

INTERPRET THIS DRAWING PER USASI Y14.5	DRAWN BY	DATE	 ATARI ATARI INCORPORATED 14600 Winchester Boulevard Los Gatos, California 95030
UNLESS OTHERWISE SPECIFIED DIMENSIONS ARE IN INCHES TOLERANCES ON:	CHECKED	8-28-75	
FRACTIONS = 1/16 X = .1	DESIGN ENGINEER		
ANGLES = 21° X = .03	PROJECT ENGINEER		
SURFACE FINISH ✓ .XXX = .010	DOCUMENT CONTROL		TITLE
MATERIAL:	APPROVED		ARCADE CRASH 'N' SCORE FOOT PEDAL ASSY
SEE PIL			SIZE
0004174			D
			DRAWING NO.
			0004174
			REV
			B
			SCALE
			SHEET 1 OF 1

4

3

2

1



ASSEMBLY TITLE / CONTROL PANEL ASSEMBLY P/L 004175

PARTS LIST SPECIFICATION Page 1 of 1

Drawn	
Checked	Mech. Eng.
Proj. Eng.	Elec. Eng.
	REV. D

Rev.	Description	Date	Apprv.	Rev.	Description	Date	Apprv.
A	PROD RFI	9/29/75					
B	Rev per ECN 1671	10/3/75					
C	Rev per ECN 1700	10/14/75					
D	Rev per ECN 1715	10/17/75					

Item	Part Number	Qty.	DESCRIPTION
1	004167	Ref	Control Panel - Bolt
2	004173	1	ABS Control Panel
3			
4	A000598-03	2	Steering Wheel Assembly
5	004233	1	Panel, Control Plate
6	A004219-03	1	Control Panel Harness
7	000567	2	Bow, Washer
8	001856	1	Bushing, Switch
9	62-009	1	Switch, LED
10	75-5124N	4	Carriage Bolts, #10-24 x 1½
11	75-010S	4	Flat Washer, #10
12	75-040	4	Lock Washer, #10
13	75-911S	4	Hex Nuts, #10-24
14	72-1124S	12	Mach Screw, #10-24 x 1½ Pan Hd Phil
15	72-6812	3	Screws, Self Tapping, Sheet Metal, #8 x 3/4
16	A004304-07	1	Double Lite Switch Assy - One Player
17	A004304-08	1	Double Lite Switch Assy - Two Player
18	004168	Ref	Control Panel - Backup

8

7

6

5

D

C

B

A

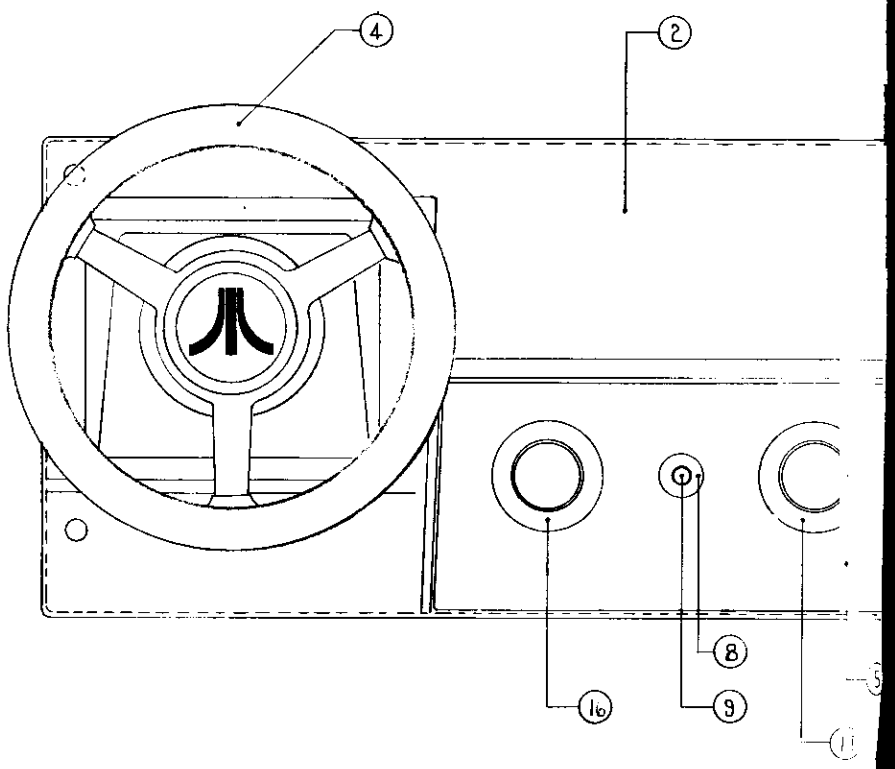
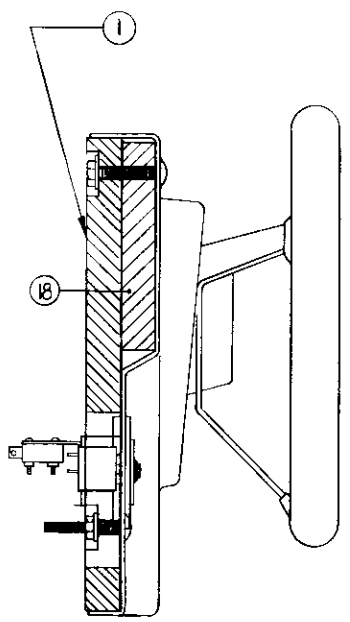
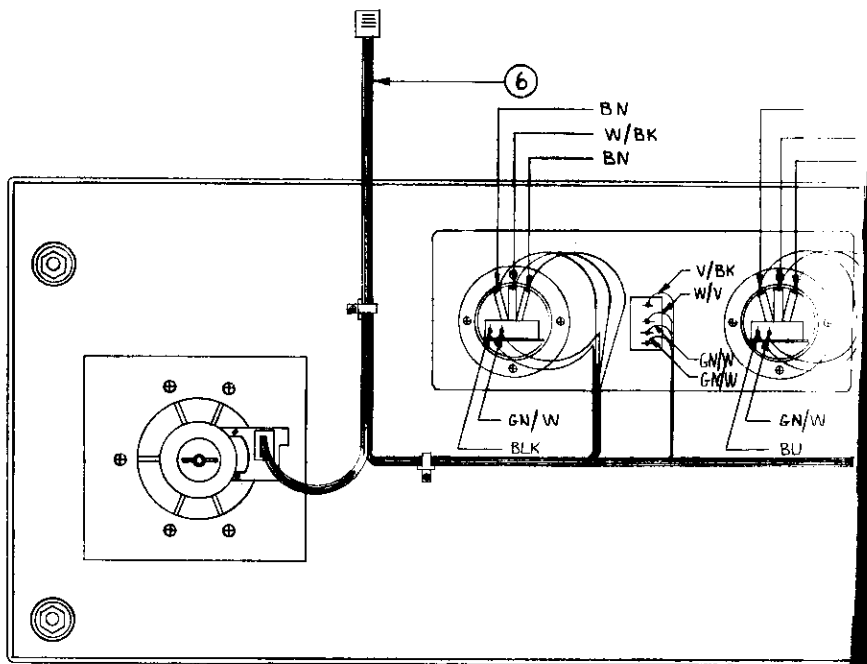

8

7

6

5

4

3

2

1

REVISIONS			
SYM	DESCRIPTION	INITIALS and DATE	
		DRFTG	CHECK
A	PROD. RELEASE	9-29-75	
B	REV. PER ECN 1671	10-3-75	
C	REV. PER ECN 1700	10-13-75	
D	REV. PER ECN 1715	10-17-75	

BN
W/BU
BN

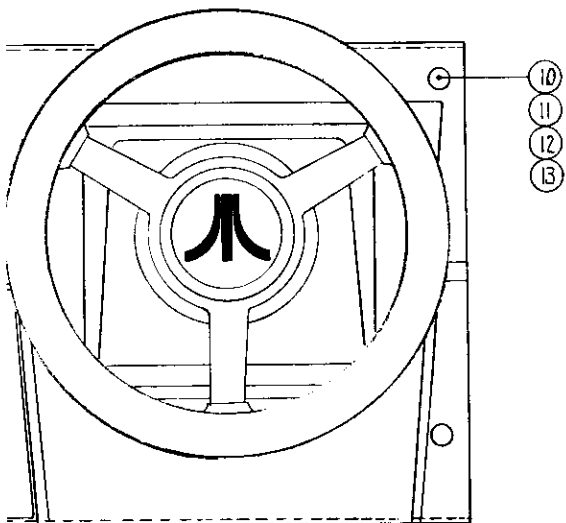
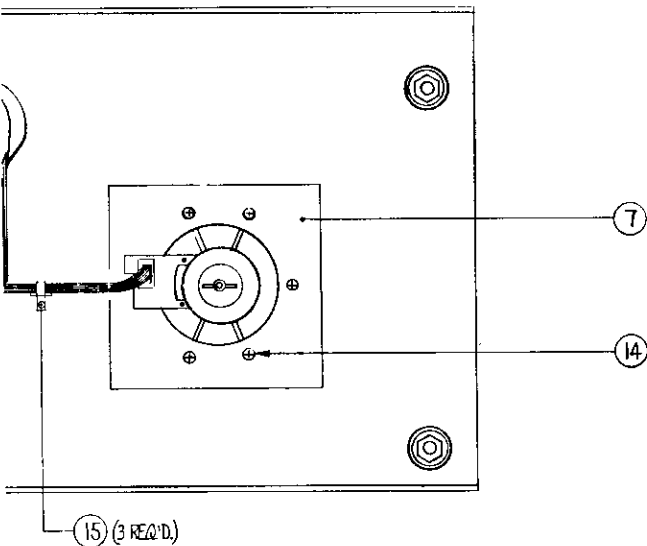

NOTICE TO ALL PERSONS RECEIVING THIS DRAWING
 CONFIDENTIAL. Reproduction Forbidden without the specific written permission of Atari Inc., Los Gatos, California. This drawing is only conditionally loaned, and neither receipt nor possession thereof confers or transfers any right in, or license to use, the subject matter of the drawing or any design or technical information shown thereon, nor any right to reproduce this drawing or any part thereof, except for manufacture by vendors for Atari Incorporated and for manufacturers under the corporation's written license, no right to reproduce this drawing is granted or the subject matter thereof, unless by written agreement with or written permission from the corporation.

ADD 4172	ARC. COA. N'SCO
NEXT ASSY	USED ON
APPLICATION	

INTERPRET THIS DRAWING PER USASI Y14.5	DRAWN BY _____ DATE 8-28-75	 ATARI INCORPORATED 14600 Winchester Boulevard Los Gatos, California 95030
UNLESS OTHERWISE SPECIFIED DIMENSIONS ARE IN INCHES TOLERANCES ON:	CHECKED _____	
FRACTIONS = 1/16 .1 * A J ANGLES = 45° .XX * A .03 SURFACE FINISH ✓ .XXX = A .010	DESIGN ENGINEER _____	TITLE ARCADE CRASH 'N' SCORE TOP ASS'Y-CONTROL PANEL
MATERIAL: STEEL P/L 004175	PROJECT ENGINEER _____	SIZE D DRAWING NO. A004175 REV D
	DOCUMENT CONTROL _____	SCALE _____ SHEET 1 OF 1
	APPROVED _____	

4

3

2

1

D

C

B

A

DRAWING NO. _____
 SHEET _____
 REV _____



REFERENCE ONLY!

ASSEMBLY TITLE SWITCH, DOUBLE LITE ASSY

P/L 003094-XXX

PARTS LIST SPECIFICATION

Page 1 of 1

Drawn	
Checked	Mech. Eng.
Proj. Eng.	Elec. Eng
	REV. E

Rev.	Description	Date	Apprv.	Rev.	Description	Date	Apprv.
A	PROD REL	1/22/75					
B	Rev per ECN 1139	2/17/75					
C	Rev per ECN 1221	3/17/75					
D	Rev per ECN 1268	5/17/75					
E	Rev per ECN 1456	5/30/75					
F	SEE F/D ECN 1776	11/17/75					

Item	Part Number	Qty.	DESCRIPTION
1	003175	1	Housing
2	A003840	1	Plunger, Lens Assembly
3			
4	003178	1	Lock Ring
5	003177	1	Switch Bracket
6	003176	*A/R	Contact
7	003180	1	Spring
8	003173	1	Actuator
9	72-14 S	4	Mntg. Screw, Pan Hd, 4-40 x Length **A/R
10	65-021C	1	Cherry Switch, G-18
11	70-13328	*A/R	Lamp, #328 Chicago Min.
12	72-1403S	*4	Screws, Pan Hd, 4-40 x 3/16" Lg
13	72-1412S	2	Screws, Pan Head, 4-40 x 3/4" Long
14	75-914S	2	Hex Nut. 4-40
15			
16	70-50X	*A/R	Lens Filter

* If "0" is not indicated in either column, 3 Contacts (003176), 3 Lamps (70-13328), and 3 additional Screws (75-1403S) will be required. If "0" is indicated in one column and a numeral in the other, 2 Contacts, 2 Lamps, and 2 additional Screws will be required.

A003094-XXX

**	MTG. SCREW LENGTH	# 1 LENS FILTER	# 2 LENS FILTER
-0	3/8	-0 NO LIGHT USED	-0 NO LIGHT USED
-1	1/2	-1 NO FILTER USED	-1 NO FILTER USED
-2	5/8	-2 RED	-2 RED
-3	3/4	-3 ORANGE	-3 ORANGE
-4	7/8	-4 YELLOW	-4 YELLOW
-5	1	-5 GREEN	-5 GREEN
		-6 BLUE	-6 BLUE

REV.	DESCRIPTION	DRAWN	CHECKED	APPROVED
A	PRODUCTION REL	1-22-75		
B	REV PER ECN 1109			
C	REV PER ECN 1221	10-13-75		
D	REV PER ECN 1244	5-17-77		
E	REV PER ECN 1458	5-29-78		

HOUSING
003175

PLUNGER, LENS ASSY
A003840

SPRING
003180

MOUNTING SCREW
003103

SWITCH BRACKET
003177

SWITCH, CHERY G-16

SCREW, MACH, RD, HD PH. 4-40 X 1" LONG
2 REQ.

* IF '0' IS NOT INDICATED IN EITHER COLUMN,
3 CONTACTS (003176), 3 LAMPS (70-13328)
AND 3 ADDITIONAL SCREWS (75-14035)
WILL BE REQUIRED. IF '0' IS INDICATED IN
THE OTHER, 2 CONTACTS, 2 LAMPS, AND
2 ADDITIONAL SCREWS WILL BE
REQUIRED.

A003094-XXX

X LENS FILTER
AS REQ'D

* LAMP 320
AS REQ'D.

LOCK RING
003178

ACTUATOR
003173

4-40 X 3/16 SCREW
4 REQ.

* CONTACT
003176, AS REQ'D.

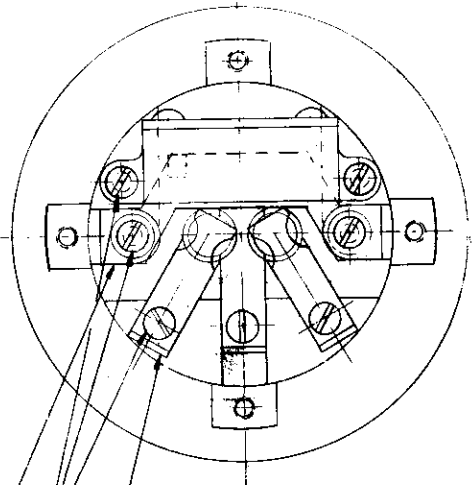
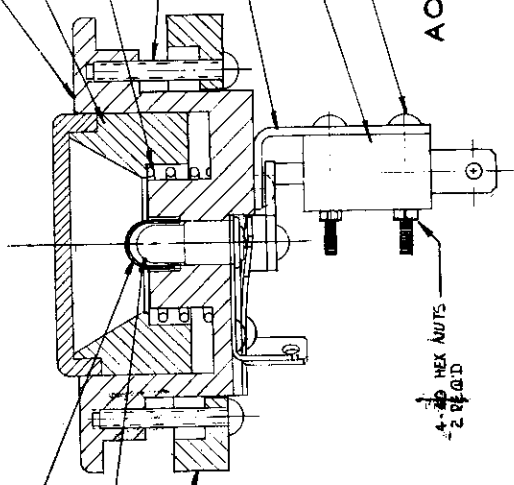

MFG. SCREW LENGTH	# 1 LENS FILTER	# 2 LENS FILTER
-0 7/8	-0 NO LIGHT USED	-0 NO LIGHT USED
-1 1/2	-1 NO FILTER USED	-1 NO FILTER USED
-2 5/8	-2 RED	-2 RED
-3 3/4	-3 ORANGE	-3 ORANGE
-4 7/8	-4 YELLOW	-4 YELLOW
-5 1	-5 GREEN	-5 GREEN
	-6 BLUE	-6 BLUE

NOTE:
THIS DRAWING REPLACED BY
A004304 AND IS TO BE
USED FOR REFERENCE ONLY.

5215-5901

A003177	
TITLE DOUBLE LITE SWITCH	
DATE	NOTED
REV 2.000	REV 1.000
CRANGES - 4 (REV)	REV 1.000
DATE	DATE
NOTE	A003094-X

REV.	DESCRIPTION	DRAWN	CHECKED	APPROVED
A	PRODUCTION REL			1-22-75
B	REV PER ECN 1109			
C	REV PER ECN 1221	18		3-17-75
D	REV PER ECN 1244	5177		
E	REV PER ECN 1428	5395		15
F	SEE NOTE 1776			ECN 1776

HOUSING
003175

PLUNGER, LENS ASSY
A003840

SPRING
003180

MOUNTING SCREW
003103

SWITCH BRACKET
003177

SWITCH, CHEEZY G-18

SCREW, MACH. RD. HD PH. 4-40 X 1" LONG
2 REQ.

* IF '0' IS NOT INDICATED IN EITHER COLUMN, 3 CONTACTS (003176), 3 LAMPS (70-13328) AND 3 ADDITIONAL SCREWS (75-14035) WILL BE REQUIRED. IF '0' IS INDICATED IN ONE COLUMN AND A NUMERICAL IN THE OTHER, 2 CONTACTS, 2 LAMPS, AND 2 ADDITIONAL SCREWS WILL BE REQUIRED.

A003094-XX

X LENS FILTER
AS REQ'D

* LAMP 1320
AS REQ'D.

LOCK RING
003178

ACTUATOR
003173

4-40 X 3/16 SCREW
4 REQ.

* CONTACT
003176, AS REQ'D.

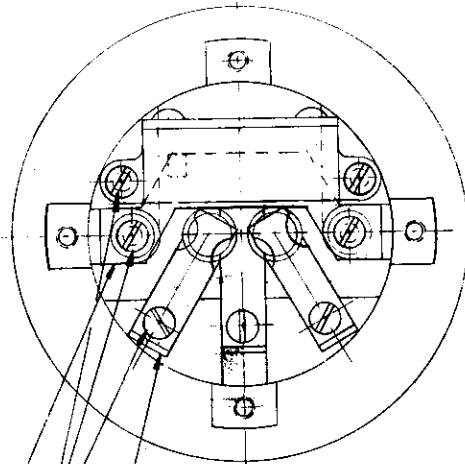
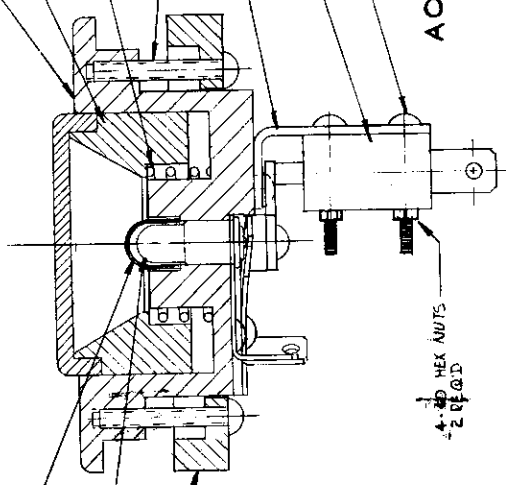

MTC. SCREW LENGTH	# 1 LENS FILTER	# 2 LENS FILTER
-0 7/8	-0 NO LIGHT USED	-0 NO LIGHT USED
-1 1/2	-1 NO FILTER USED	-1 NO FILTER USED
-2 5/8	-2 RED	-2 RED
-3 3/4	-3 ORANGE	-3 ORANGE
-4 7/8	-4 YELLOW	-4 YELLOW
-5 1	-5 GREEN	-5 GREEN
	-6 BLUE	-6 BLUE

NOTE:
THIS DRAWING REPLACED BY
A004304 AND IS TO BE
USED FOR REFERENCE ONLY.

3215-3901

TITLE DOUBLE LIFE SWITCH	
DATE	NOTED
BY	CHK'D
APP'D	DATE
NOTE	A003094

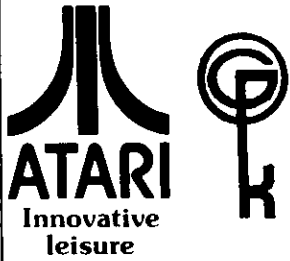

ASSEMBLY TITLE / STEERING WHEEL ASSEMBLY P/L 000598-0

PARTS LIST SPECIFICATION Page 1 of 1

Drawn	
Checked	Mech. Eng.
Proj. Eng.	Elec. Eng
	REV. H

Rev.	Description	Date	Apprv.	Rev.	Description	Date	Apprv.
H	Rev per ECN 1591	8/26/75					

Item	Part Number	Qty.	DESCRIPTION
1	000598	Ref	Steering Wheel Assy (3201-3803)
2	000599	1	Cover
3	000605	1	Housing (3201-3545)
4	000606	1	Shaft (3201-3544)
5			
6	72-7512	3	Screw, Mach, Fil. Hd, Phil, # $\frac{1}{4}$ -20 x 3/4" Lg.
7	A000607	1	Printed Circuit Assy
8			
9	75-07002	2	Washer, Fender, $\frac{1}{4}$
10			
11	76-042020	1	Bearing, Thompson (20L20-F)
12	76-041010	1	Bearing, Thompson (10L10-F)
13	78-40102	1	Steering Wheel, 10"
14	75-945N	1	Nut, # $\frac{1}{4}$ -20, Nylon Lock
15	72-9580	1	Screw, Mach, Truss Hd, Slotted, # $\frac{1}{4}$ -20 x 5 Lg.
16	000616	1	Hub Light
17	75-055	1	Washer, $\frac{1}{4}$ " Int. Tooth, Starlock
18	78-16002	A/R	Silicone Grease, Compound
19	73-1208	2	Mach Screw, .256 x $\frac{1}{2}$ Pan Hd Phil

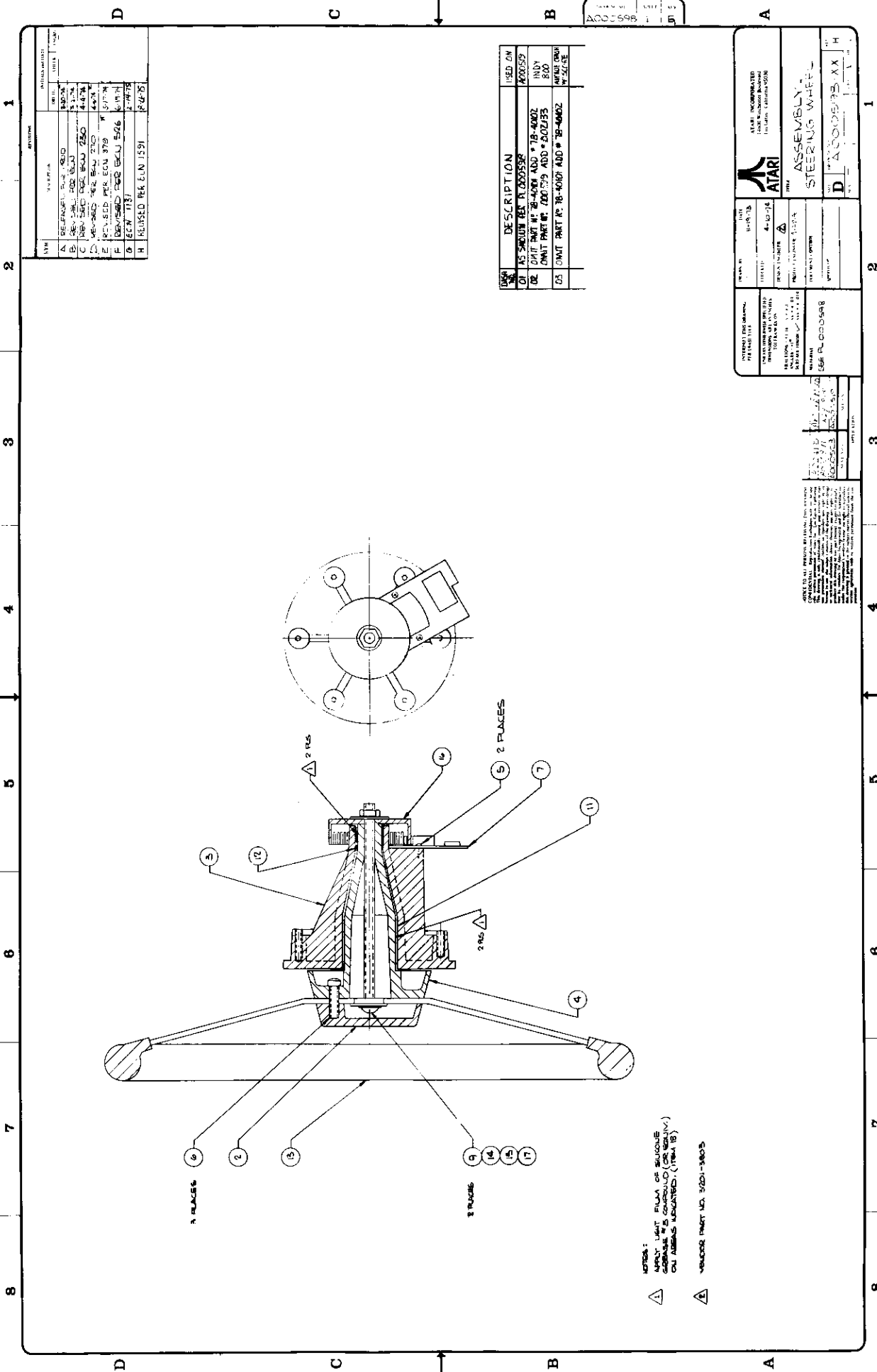

ITEM	QUANTITY	DESCRIPTION	UNIT	REVISION
A	1	DEFINITE - 20-4000	PCB	1
B	1	DEFINITE - 20-4000	PCB	1
C	1	DEFINITE - 20-4000	PCB	1
D	1	DEFINITE - 20-4000	PCB	1
E	1	DEFINITE - 20-4000	PCB	1
F	1	DEFINITE - 20-4000	PCB	1
G	1	DEFINITE - 20-4000	PCB	1
H	1	DEFINITE - 20-4000	PCB	1

ITEM	DESCRIPTION	USED ON
01	AS SHOWN PER N 000558	000519
02	OMIT PART # 78-4002 AND * 78-4002	1000
03	OMIT PART # 78-4002 ADD * 202135	800
04	OMIT PART # 78-4002 ADD * 78-4002	1000
05	OMIT PART # 78-4002 ADD * 78-4002	1000

NOTES:
 ▲ APPLY LIGHT FILM OF SILICONE GREASE # 5 COMPOUND (OR EQUIV.) ON AREAS INDICATED. (ITEM 18)
 ▲ VENDOR PART NO. 30201-100'S

 ATARI CORPORATION 1400 17TH AVENUE BERKELEY, CALIFORNIA 94708	PART NO. 20-4000 REV. 4-10-78 DRAWN BY: [Signature] CHECKED BY: [Signature] APPROVED BY: [Signature]
PART NO. 20-4000 REV. 4-10-78 DRAWN BY: [Signature] CHECKED BY: [Signature] APPROVED BY: [Signature]	PART NO. 20-4000 REV. 4-10-78 DRAWN BY: [Signature] CHECKED BY: [Signature] APPROVED BY: [Signature]

NOTE TO ALL PERSONS BEHAVING FOR ANY OF THE FOLLOWING REASONS: THIS DRAWING IS THE PROPERTY OF ATARI CORPORATION AND IS LOANED TO YOU BY ATARI CORPORATION. IT IS TO BE USED ONLY FOR THE PURPOSES SPECIFIED BY THE DRAWING. IT IS NOT TO BE REPRODUCED, COPIED, OR TRANSMITTED IN ANY FORM OR BY ANY MEANS, ELECTRONIC OR MECHANICAL, INCLUDING PHOTOCOPYING, RECORDING, OR BY ANY INFORMATION STORAGE AND RETRIEVAL SYSTEM. WITHOUT THE WRITTEN PERMISSION OF ATARI CORPORATION, THIS DRAWING IS NOT TO BE USED FOR ANY OTHER PURPOSE. ANY VIOLATION OF THESE TERMS SHALL BE CONSIDERED A BREACH OF CONTRACT AND SHALL BE SUBJECT TO LEGAL ACTION.

PART NO. 20-4000 REV. 4-10-78 DRAWN BY: [Signature] CHECKED BY: [Signature] APPROVED BY: [Signature]	PART NO. 20-4000 REV. 4-10-78 DRAWN BY: [Signature] CHECKED BY: [Signature] APPROVED BY: [Signature]
--	--

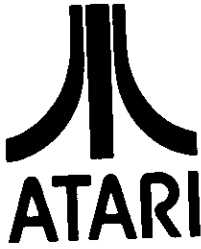

Job Title RACETRAK STEERING PCB ASSY Dwg. P/L 000607

Parts List Specification sheet 1 of 1

Drawn		Rev. M
Checked	Mech. Eng.	
Proj. Eng.	Elec. Eng.	

Rev.	Description	Apprv.	Rev.	Description	Apprv.
H	Redesigned	5-8-74			
J	Rev per ECN 397	5/28/74			
K	Rev per ECN 457	6/3/74			
L	Rev per ECN 601	7/15/74			
M	Rev per ECN 1531				

Item	Part. No.	Qty.	Description
1	000614	1	Printed Circuit Board (E)
2	001092	1	Light Mount
3	001151	Ref	Schematic Diagram
4	11750/10-5750	2	Resistor, Comp., 75 ohm, 1/4 watt, 5%
5	11471/10-5471	4	Resistor, Comp, 470 ohm, 1/4 watt, 5%
6	11332/10-5332	2	Resistor, Comp, 3.3Kohm, 1/4 watt, 5%
7	34104 /27-101103	2	Capacitor, Ceramic, .01uf
8	70006/38-2N5777	2	Transistor, 2N 5777 (Photo Darlington)
9	70000/34-2N3643	2	Transistor, 2N 3643
10	71008/38-ME7124	2	Light Emitting Diode, I.R. ME 7124
11			
12			
13			
14	80089 /79-58005	1	Connector, 10 pin, PC Mount, Amp #1-380991
15	72-1212S	1	Screw, Machine, Pan Head Phil, #2-56 x 3/4 Lg.
16	75-042	1	Washer, Split Lock #2
17	75-912S	1	Nut, Hex, #2-56
18	003749	1	Retainer, Led Light Mount

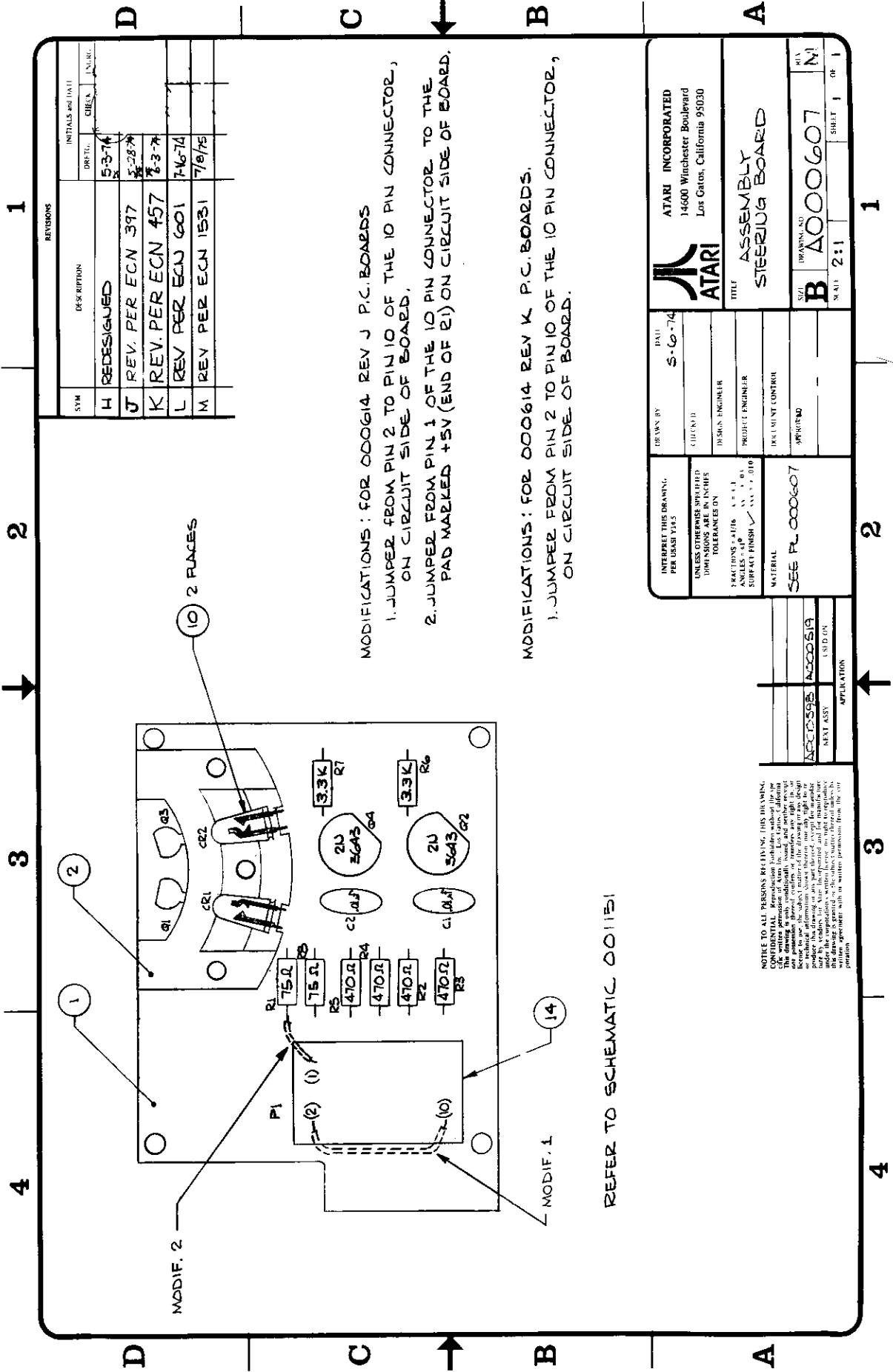

REVISIONS		INITIALS AND DATE	
SYM	DESCRIPTION	DRFT.	CHKD.
H	REDESIGNED	5-3-74	
J	REV. PER ECN 397	5-28-74	
K	REV. PER ECN 457	7-3-74	
L	REV. PER ECN 601	7-16-74	
M	REV. PER ECN 1531	7/8/75	

MODIFICATIONS: FOR 000614 REV J P.C. BOARDS

1. JUMPER FROM PIN 2 TO PIN 10 OF THE 10 PIN CONNECTOR, ON CIRCUIT SIDE OF BOARD.
2. JUMPER FROM PIN 1 OF THE 10 PIN CONNECTOR TO THE PAD MARKED +5V (END OF R1) ON CIRCUIT SIDE OF BOARD.

MODIFICATIONS: FOR 000614 REV K P.C. BOARDS.

1. JUMPER FROM PIN 2 TO PIN 10 OF THE 10 PIN CONNECTOR, ON CIRCUIT SIDE OF BOARD.

REFER TO SCHEMATIC 001151

INTERPRET THIS DRAWING PER USAS 7142	DRAWN BY S-G-74	PAID 5-6-74	ATARI INCORPORATED 14600 Winchester Boulevard Los Gatos, California 95030
UNLESS OTHERWISE SPECIFIED DIMENSIONS ARE IN INCHES TOLERANCES ON	CHECKED	DESIGN ENGINEER	ATARI
FRACTIONS - 1/16, 1/8, 1/4, 3/8, 1/2, 5/8, 3/4, 7/8, 1, 1 1/8, 1 1/4, 1 1/2, 1 3/4, 2, 2 1/4, 2 1/2, 3, 3 1/4, 3 1/2, 4, 4 1/4, 4 1/2, 5, 5 1/4, 5 1/2, 6, 6 1/4, 6 1/2, 7, 7 1/4, 7 1/2, 8, 8 1/4, 8 1/2, 9, 9 1/4, 9 1/2, 10, 10 1/4, 10 1/2, 11, 11 1/4, 11 1/2, 12, 12 1/4, 12 1/2, 13, 13 1/4, 13 1/2, 14, 14 1/4, 14 1/2, 15, 15 1/4, 15 1/2, 16, 16 1/4, 16 1/2, 17, 17 1/4, 17 1/2, 18, 18 1/4, 18 1/2, 19, 19 1/4, 19 1/2, 20	PROJECT ENGINEER	PLACEMENT CONTROL	ASSEMBLY STEERING BOARD
MATERIAL	APPROVED	DATE	REV. NO.
SEE PL 000607			
APPROVED: ACC0519			
UNLSD ON			
APPLICATION			

NOTICE TO ALL PERSONS RECEIVING THIS DRAWING: THIS DRAWING IS THE PROPERTY OF ATARI INC. AND IS LOANED TO YOU BY ATARI INC. IT IS TO BE USED ONLY FOR THE PROJECT AND FOR WHICH IT WAS PREPARED. IT IS NOT TO BE REPRODUCED, COPIED, OR TRANSMITTED IN ANY FORM OR BY ANY MEANS, ELECTRONIC OR MECHANICAL, INCLUDING PHOTOCOPYING, RECORDING, OR BY ANY INFORMATION STORAGE AND RETRIEVAL SYSTEM. WITHOUT THE WRITTEN PERMISSION OF ATARI INC., THIS DRAWING IS NOT TO BE USED FOR ANY OTHER PROJECT OR IN ANY OTHER MANNER. ATARI INC. ACCEPTS NO LIABILITY FOR ANY DAMAGE OR LOSS OF PROFITS, BUSINESS, OR REPUTATION, OR FOR ANY SPECIAL, CONSEQUENTIAL, OR INCIDENTAL DAMAGES, INCLUDING LOST PROFITS, BUSINESS, OR REPUTATION, ARISING OUT OF OR IN CONNECTION WITH THE USE OF THIS DRAWING.

44 POS TRANS 001551
EDGE CONNECTOR

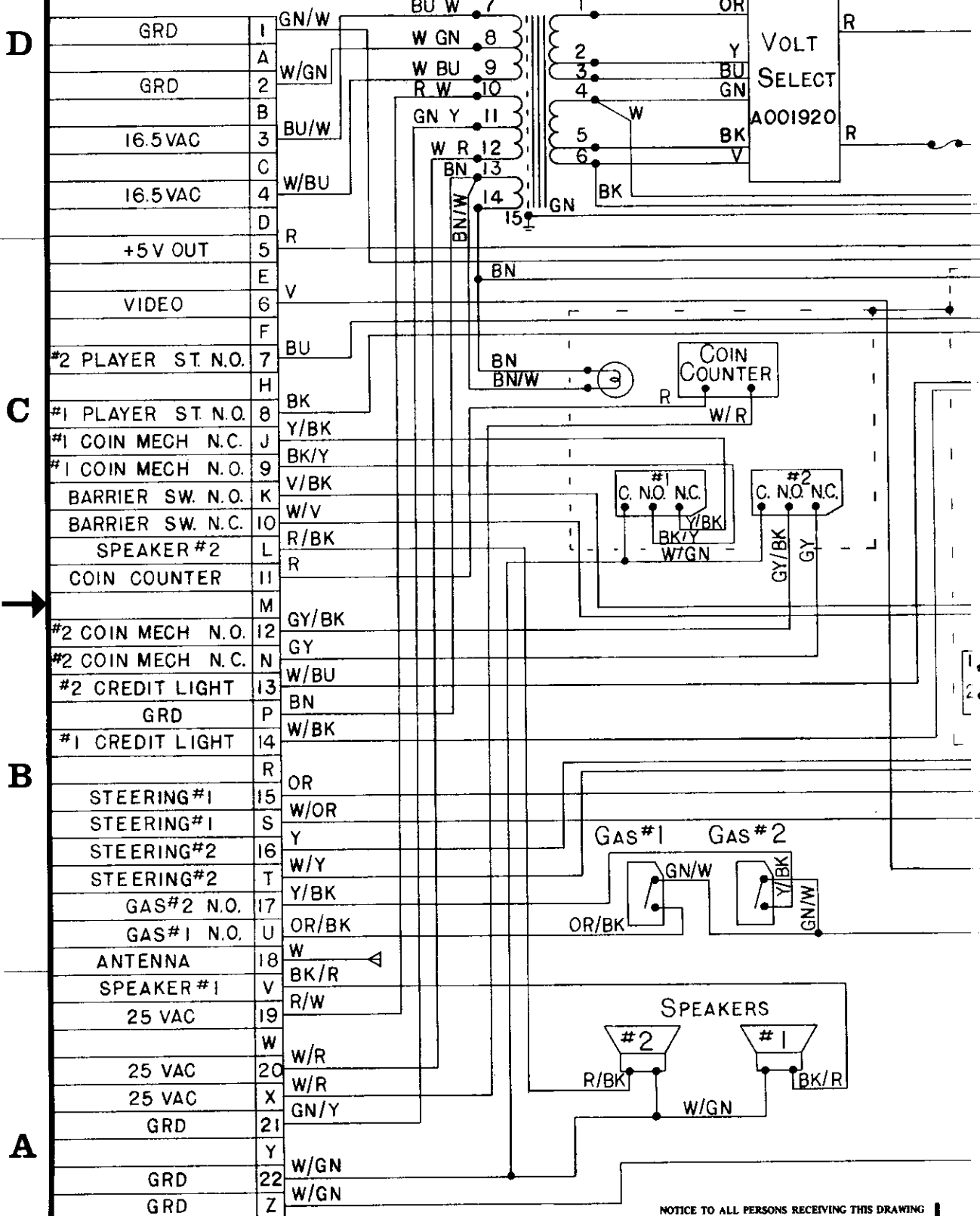

NOTICE TO ALL PERSONS RECEIVING THIS DRAWING
 CONFIDENTIAL: Reproduction Forbidden without the specific written permission of Atari Inc., Los Gatos, California. This drawing is only conditionally issued, and neither receipt nor possession thereof confers or transfers any right in, or license to me, the subject matter of the drawing or any design or technical information shown thereon, nor any right to reproduce this drawing or any part thereof, except for manufacture by vendors for Atari Incorporated and for manufacture under the corporation's written license, no right to reproduce this drawing is granted or the subject matter thereof unless by written agreement with or written permission from the corporation.

REVISIONS				
SYM	DESCRIPTION	INITIALS and DATE		
		DRAFT	CHECK	ENGRG
A	PROD. REL.	<i>10/15/75</i>		
B	REV PER ECN 1704	10-15-75		

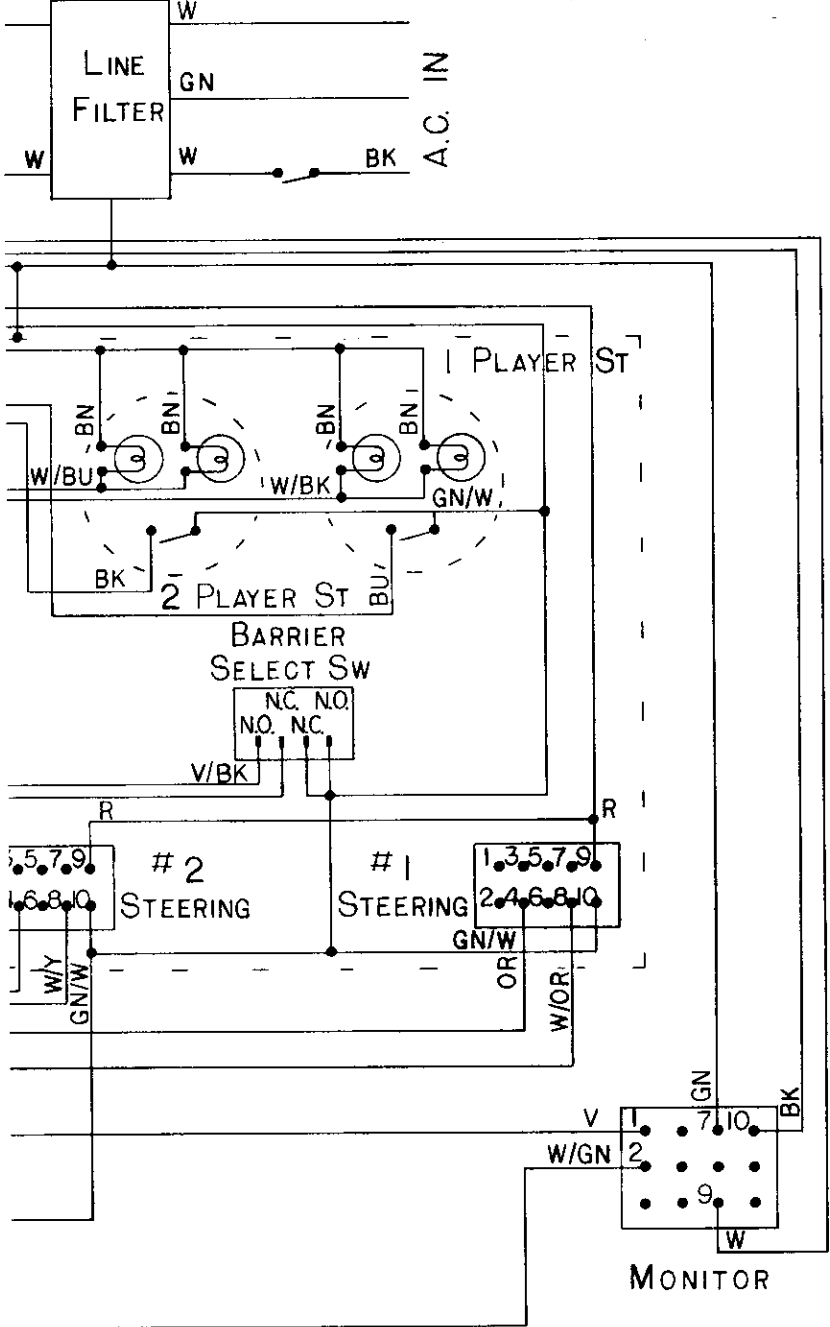

D
C
B
A

DRAWING NO.
SHEET
REV

<p>INTERPRET THIS DRAWING PER USASI Y14.5</p> <p>UNLESS OTHERWISE SPECIFIED DIMENSIONS ARE IN INCHES TOLERANCES ON:</p> <p>FRACTIONS = ±1/16 .x = ±.1 ANGLES = ±1° .xx = ±.03 SURFACE FINISH ✓ .xxx = ±.010</p> <p>MATERIAL:</p>	<p>DRAWN BY</p> <p>DATE 10-7-75</p>	 <p>ATARI INCORPORATED 14600 Winchester Boulevard Los Gatos, California 95030</p>	
	<p>CHECKED</p>		<p>TITLE</p> <p>ARCADE CRASH N SCORE HARNESS SCHEMATIC</p>
	<p>DESIGN ENGINEER</p>		<p>SIZE C</p>
	<p>PROJECT ENGINEER</p>		<p>DRAWING NO. 004218</p>
	<p>DOCUMENT CONTROL</p>		<p>REV B</p>
<p>APPROVED</p>	<p>SCALE</p>	<p>SHEET OF </p>	

ISSY	USED ON
APPLICATION	

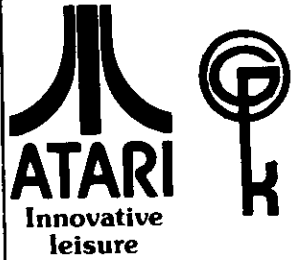

PARTS LIST SPECIFICATION

Drawn		Rev.	
Checked		Mech. Eng.	
Proj. Eng.		Elec. Eng.	

Rev.	Description	Date	Apprv.	Rev.	Description	Date	Apprv.
A	PROD REL	10.8.75					

Item	Part Number	Qty.	DESCRIPTION
1	004176	1	Tray, Electronics
2	001551	1	Transformer
3	72-6608	14	Screw, Sht. Metal, Pan Hd., Phil., #6 x 1/2 Lg.
4	000622	1	Cover, Transformer
5	79-3201	1	Fuse Holder
6	46-201132	1	Fuse, 1.25 Amp
7	90-3001	1	Filter, Power Line
8	68-001	1	A.C. Power Interlock Switch
9	000268	1	Bracket, Switch Mtg.
10	A004244	1	Power Cord Assembly, 8'
11	A002808-03	1	Interlock Switch Jumper
12	72-6812	4	Screw, SM, Pan Hd., Phil., #8 x 3/4 Lg.
13	A004217	1	Harness
14	A001920	1	Harness, Voltage Selection
15	A001921-01	1	Shorting Block, 95V
16	A001921-02	1	Shorting Block, 110V
17	A001921-03	1	Shorting Block, 220V H
18	A001921-04	1	Shorting Block, 220V L
19	A003100-04	1	Fuse Jumper Harness
20	000871	1	Label

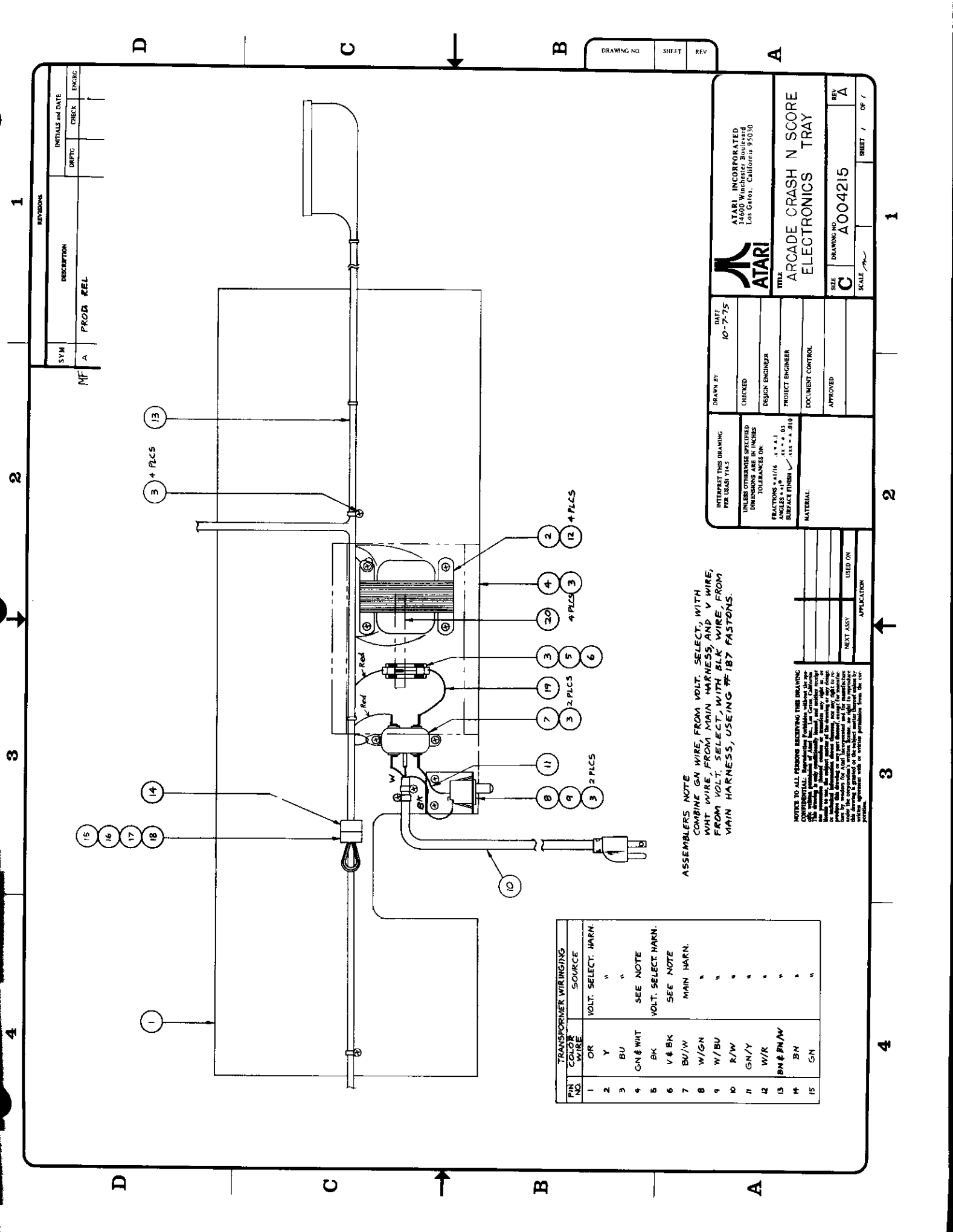

KEYS		INITIALS and DATE	
SYM	DESCRIPTION	DRAFTS	CHECK
MF	PROD REL		

DRAWING NO.	SHEET	REV
-------------	-------	-----

ATARI
 ATARI INCORPORATED
 14600 Winchester Boulevard
 Los Gatos, California 95030

TITLE: **ARCADE CRASH N SCORE ELECTRONICS TRAY**

DATE: 10-7-75

DRAWN BY: []
 CHECKED: []
 DESIGN ENGINEER: []
 PROJECT ENGINEER: []
 DOCUMENT CONTROL: []
 APPROVED: []

INTERPRET THIS DRAWING PER USER 1142

UNLESS OTHERWISE SPECIFIED TOLERANCES ON DIMENSIONS ARE IN INCHES

FRACTIONS = 1/16, 1/8, 1/4, 1/2, 3/4, 1

ANGLES = 15°

SURFACE FINISH = 111, 112, 113, 114, 115, 116, 117, 118, 119, 120, 121, 122, 123, 124, 125, 126, 127, 128, 129, 130, 131, 132, 133, 134, 135, 136, 137, 138, 139, 140, 141, 142, 143, 144, 145, 146, 147, 148, 149, 150, 151, 152, 153, 154, 155, 156, 157, 158, 159, 160, 161, 162, 163, 164, 165, 166, 167, 168, 169, 170, 171, 172, 173, 174, 175, 176, 177, 178, 179, 180, 181, 182, 183, 184, 185, 186, 187, 188, 189, 190, 191, 192, 193, 194, 195, 196, 197, 198, 199, 200

MATERIAL: []

SIZE: C
 DRAWING NO: A004215
 SHEET: 1 OF 1

ASSEMBLERS NOTE
 COMBINE GN WIRE FROM VOLT. SELECT, WITH WHT WIRE FROM MAIN HARNESS, AND V WIRE FROM VOLT. SELECT, WITH BLK WIRE, FROM MAIN HARNESS, USING #187 FASTONS.

NOTICE TO ALL PERSONS RECEIVING THIS DRAWING: THIS DRAWING IS THE PROPERTY OF ATARI INCORPORATED. IT IS TO BE USED ONLY FOR THE PURPOSES INTENDED BY ATARI INCORPORATED. IT IS TO BE KEPT IN CONFIDENCE AND NOT TO BE REPRODUCED OR TRANSMITTED IN ANY FORM OR BY ANY MEANS, ELECTRONIC OR MECHANICAL, INCLUDING PHOTOCOPYING, RECORDING, OR BY ANY INFORMATION STORAGE AND RETRIEVAL SYSTEM. WITHOUT THE WRITTEN PERMISSION OF ATARI INCORPORATED, THIS DRAWING IS NOT TO BE USED FOR ANY OTHER PURPOSE.

PIN NO.	TRANSFORMER WIRING COLOR	SOURCE
1	OR	VOLT. SELECT. HARN.
2	Y	"
3	BU	"
4	GN & WHT	SEE NOTE
5	BK	VOLT. SELECT. HARN.
6	V & BK	SEE NOTE
7	BU/W	MAIN HARN.
8	W/GN	"
9	W/BU	"
10	R/W	"
11	GN/Y	"
12	W/R	"
13	BN & BN/W	"
14	BN	"
15	GN	"

D

C

B

A

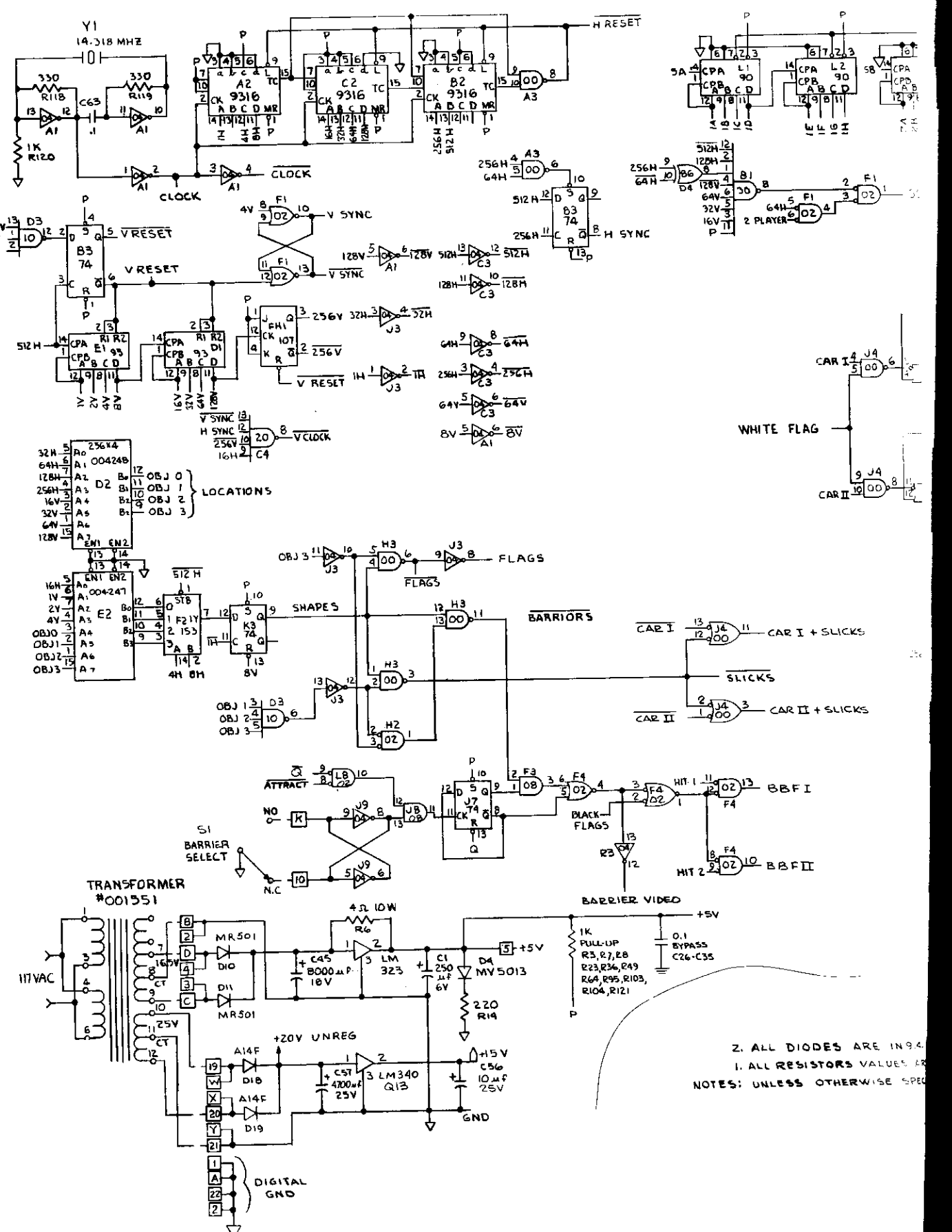

2. ALL DIODES ARE 1N94.
 1. ALL RESISTORS VALUES ARE
 NOTES: UNLESS OTHERWISE SPEC

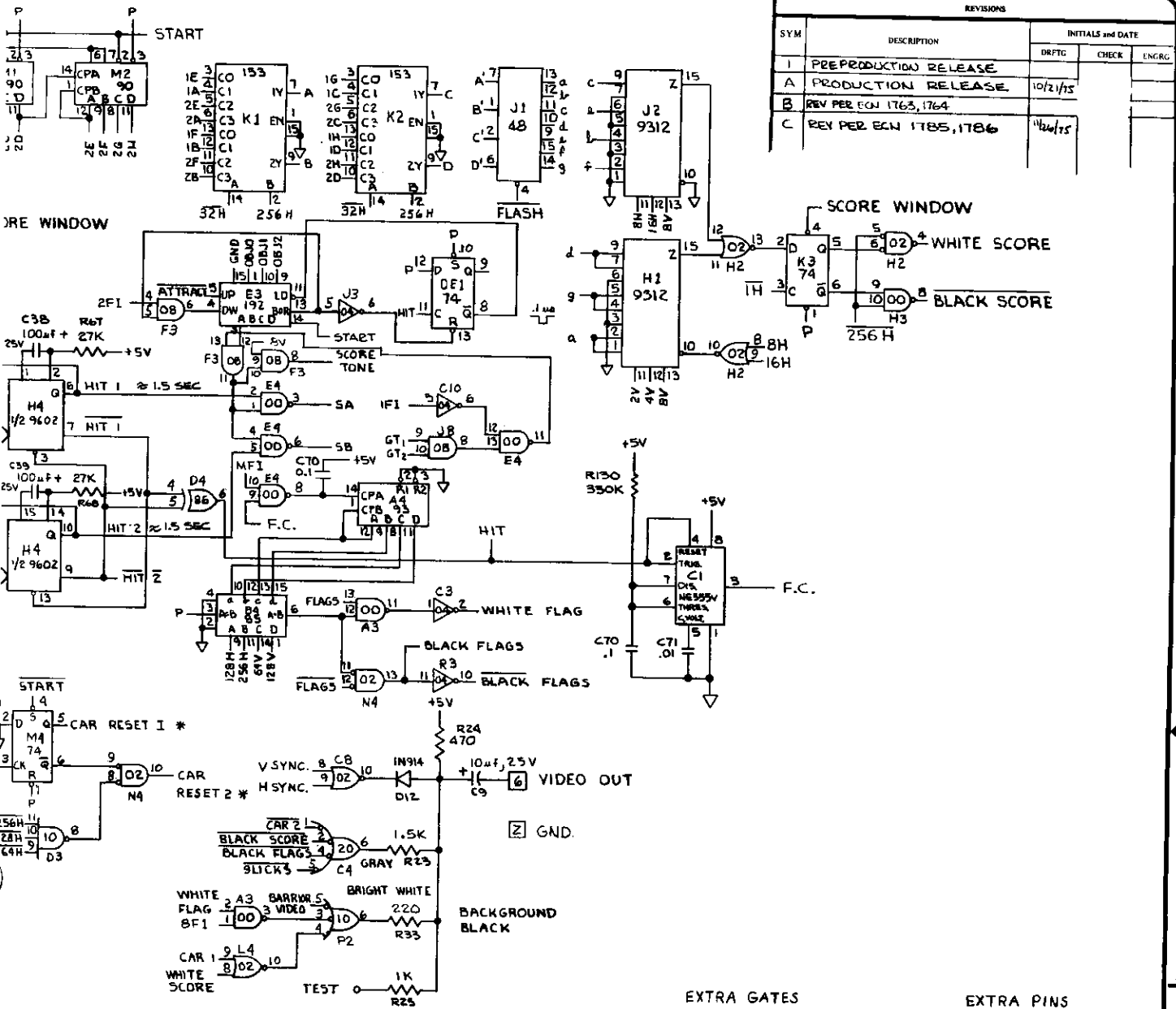

REVISIONS			
SYM	DESCRIPTION	INITIALS and DATE	
		DRFTG	CHECK ENGRG
I	PREPRODUCTION RELEASE		
A	PRODUCTION RELEASE		10/21/75
B	REV PER EGN 1763, 1764		
C	REV PER EGN 1785, 1786		11/24/75

- EXTRA GATES
- 86 - D4, D4
 - 04 - C10,
 - 32 - R4
 - 279 - MN2, MN2, MN2
 - 9602 - R1
 - 08 - MN1
 - 107 - FH1
 - 74 - DE1

- EXTRA PINS
- | |
|---|
| A |
| R |
| E |
| F |
| M |
| I |

- LAST REF. DESIG.
- D26
 - Q13
 - C71
 - R130
 - S2
 - Y1

10 OHMS, 1/4W, 10%

NOTICE TO ALL PERSONS RECEIVING THIS DRAWING
 CONFIDENTIAL. Reproduction Forbidden without the specific written permission of Atari Inc., Los Gatos, California. The drawing is only conditionally loaned, and neither receipt therefor nor possession thereof confers or transfers any right in, or or technical information shown thereon, nor any right to reproduce the drawing or any part thereof, except for manufacturing purposes by vendors for Atari Incorporated and for manufacturers under the corporation's written license; no right to reproduce the drawing is granted or the subject matter thereof shall be without agreement with or written permission from the corporation.

CRASH N' SCORE	USED ON
NEXT ASSY	APPLICATION

INTERPRET THIS DRAWING PER USASI Y14.5 UNLESS OTHERWISE SPECIFIED DIMENSIONS ARE IN INCHES TOLERANCES ON: FRACTIONS = ±1/16 X ±.1 ANGLES = ±1° XX ±.03 SURFACE FINISH ✓ XXX ±.010	DRAWN BY _____ DATE 9/8/75 CHECKED _____ DESIGN ENGINEER _____ PRODUCT ENGINEER _____ DOCUMENT CONTROL _____ APPROVED _____	ATARI INCORPORATED 14600 Winchester Boulevard Los Gatos, California 95030		
	TITLE SCHEMATIC CRASH N' SCORE			
	SIZE D		DRAWING NO 004256	REV C
	SCALE -		SHEET 1 OF 4	

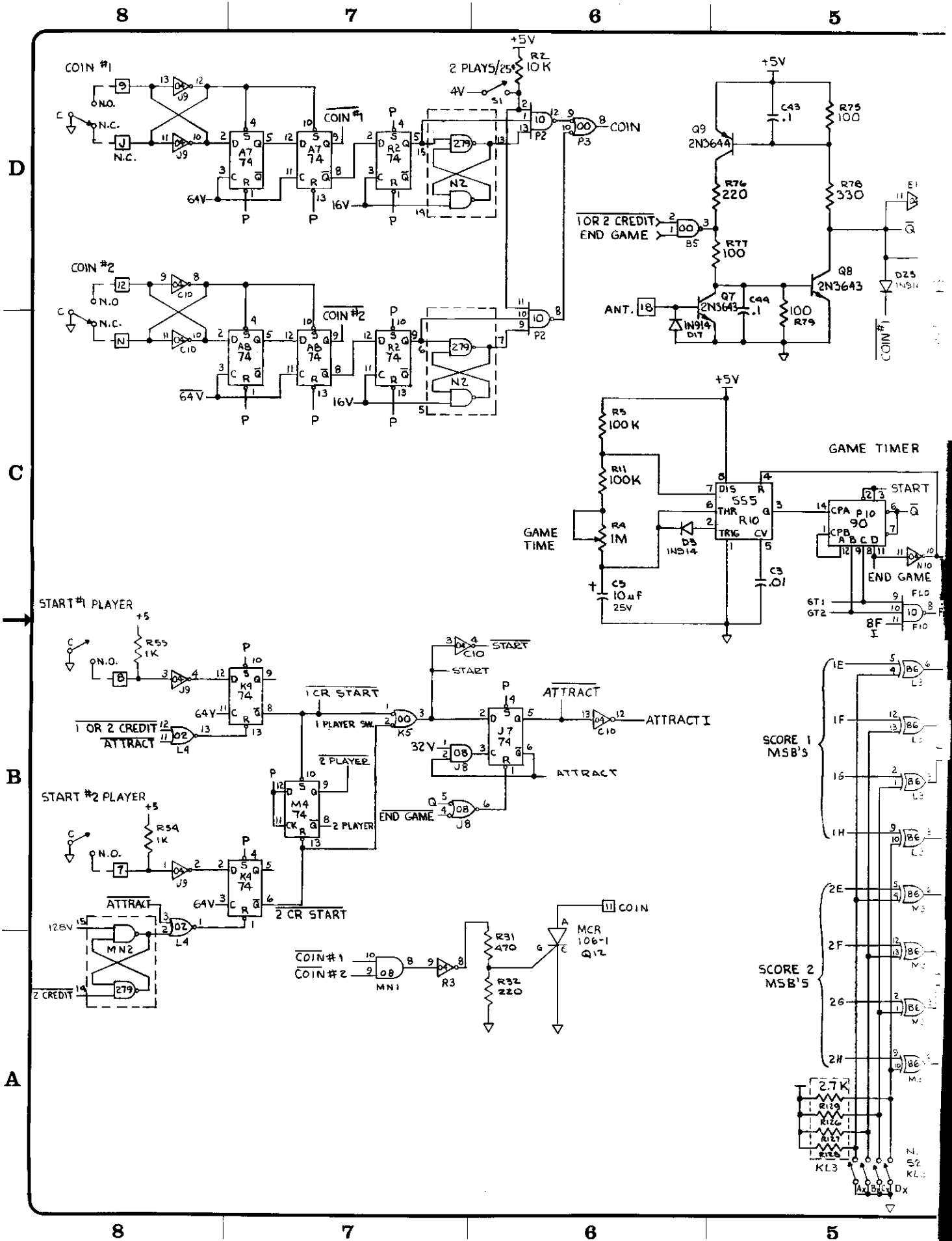

REVISIONS			
SYM	DESCRIPTION	INITIALS and DATE	
		DRAWN	CHECKED
MP	SEE SH1 1		

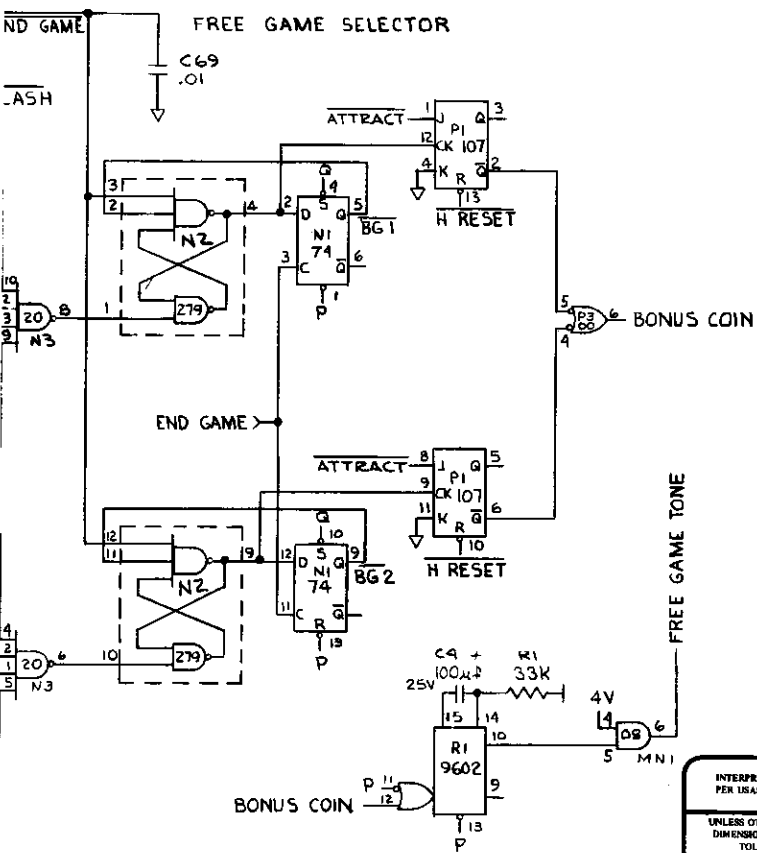
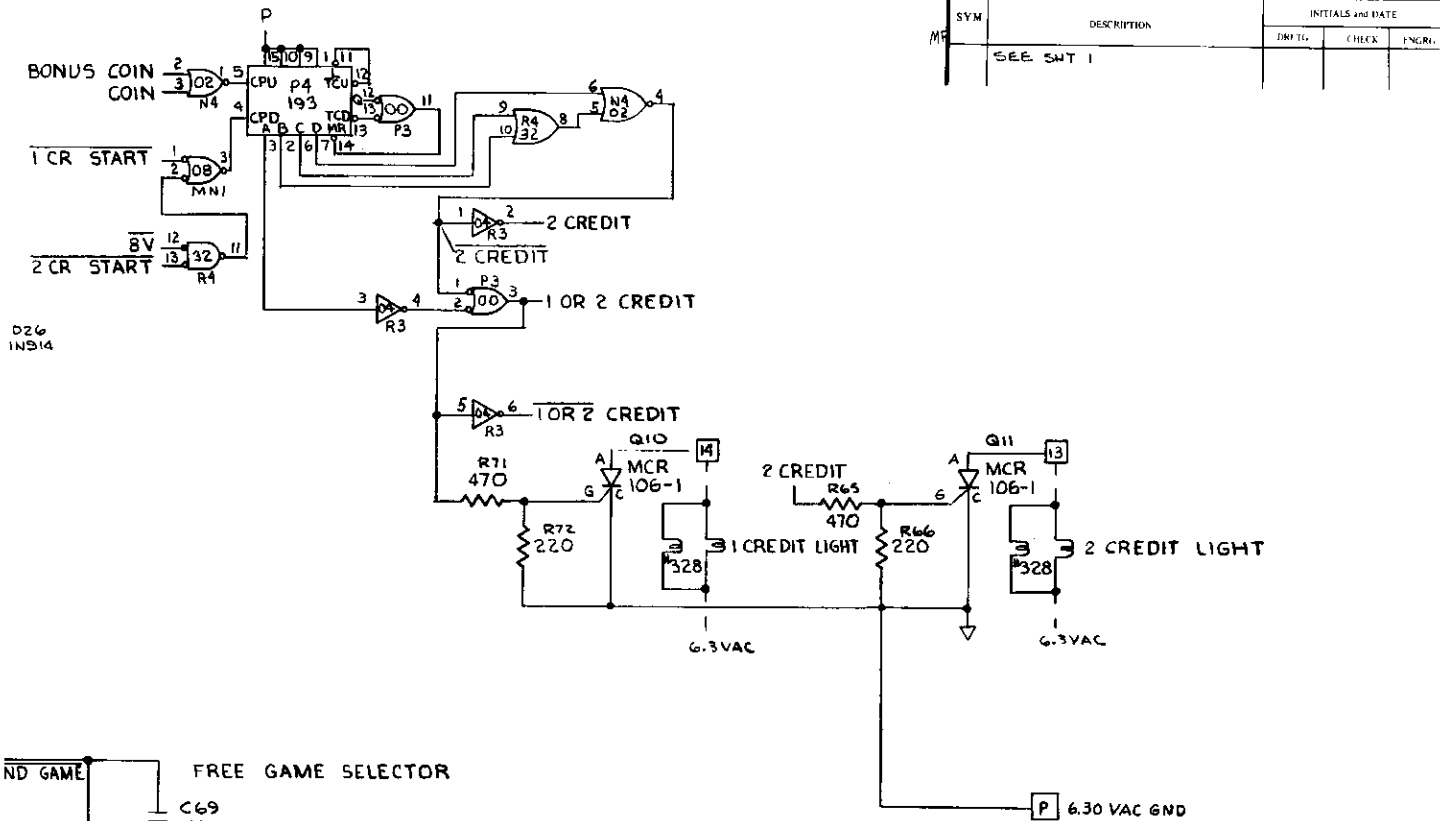

NOTICE TO ALL PERSONS RECEIVING THIS DRAWING
 CONFIDENTIAL: Reproduction Forbidden without the specific written permission of Atari Inc., Los Gatos, California. This drawing is only conditionally issued, and neither accepts nor assumes (inferred) orders or transfers any right in, or claims to any, the subject matter of the drawing or any design or technical information shown thereon, nor any right to reproduce this drawing or any part thereof, except for manufacture by vendors for Atari Incorporated and for manufacture under the corporation's written license, no right to reproduce this drawing is granted or the subject matter thereof unless by written agreement with or written permission from the corporation.

APPLICATION	
NEXT ASSY	USED ON

INTERPRET THIS DRAWING PER USASI V14.5 UNLESS OTHERWISE SPECIFIED DIMENSIONS ARE IN INCHES TOLERANCES ON: FRACTIONS = ±1/16 .5 = ±.1 ANGLES = ±1° .25 = ±.03 SURFACE FINISH ✓ .025 = ±.010	DRAWN BY	DATE	 ATARI INCORPORATED 14600 Winchester Boulevard Los Gatos, California 95030
	CHECKED		
	DESIGN ENGINEER		
	PROJECT ENGINEER		
MATERIAL:	DOCUMENT CONTROL		TITLE SCHEMATIC CRASH N'SCORE
APPROVED		SIZE D	
		DRAWING NO	REV
		004256	C
SCALE		SHEET	2 OF 4

D
C
B
A

DRAWING NO
SHEET
REV

8

7

6

5

D

C

B

A

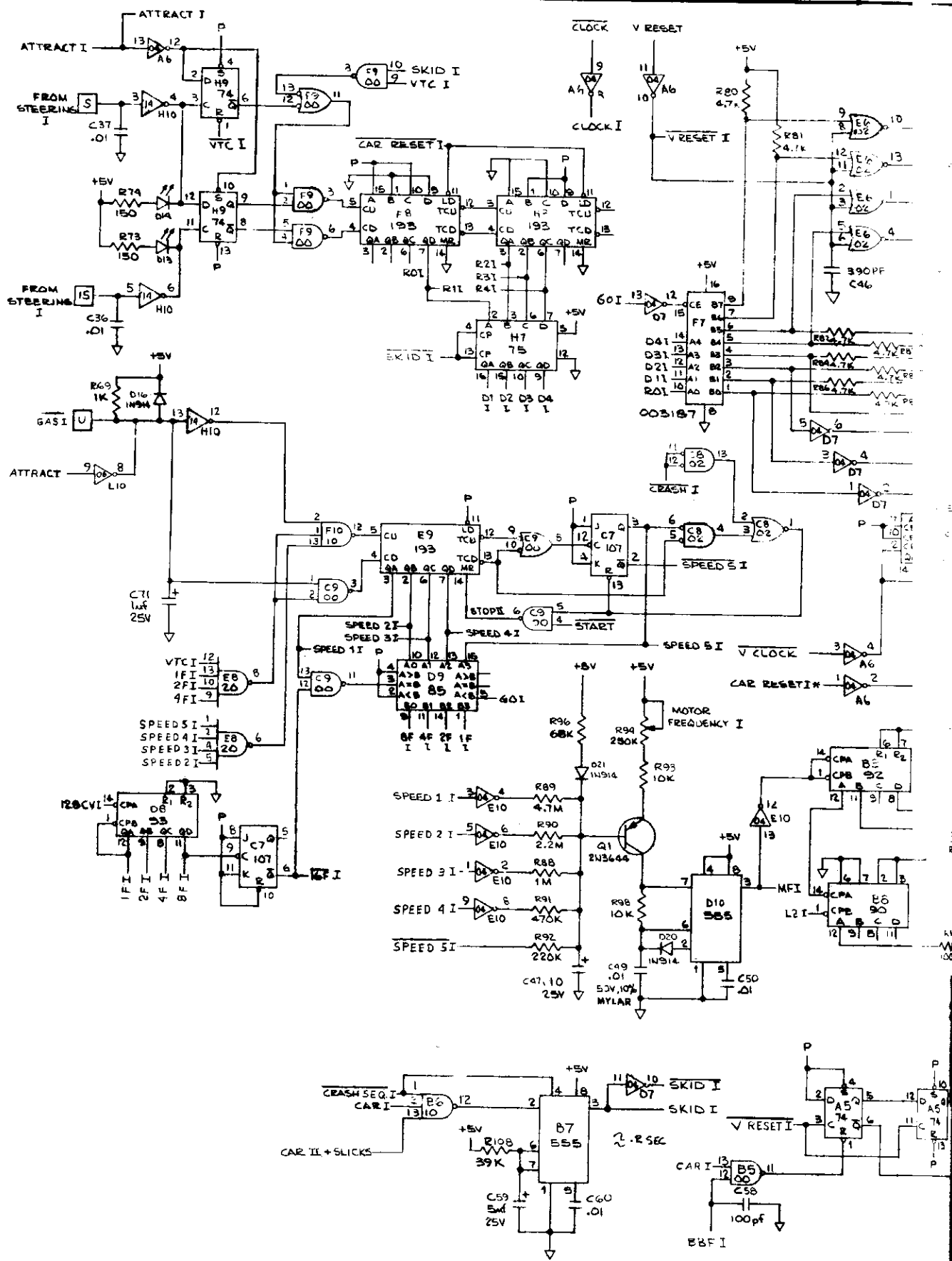

8

7

6

5

REVISIONS			INITIALS and DATE		
SYM	DESCRIPTION		ORIG	CHK	ENGR
MF	SEE SHT 1				

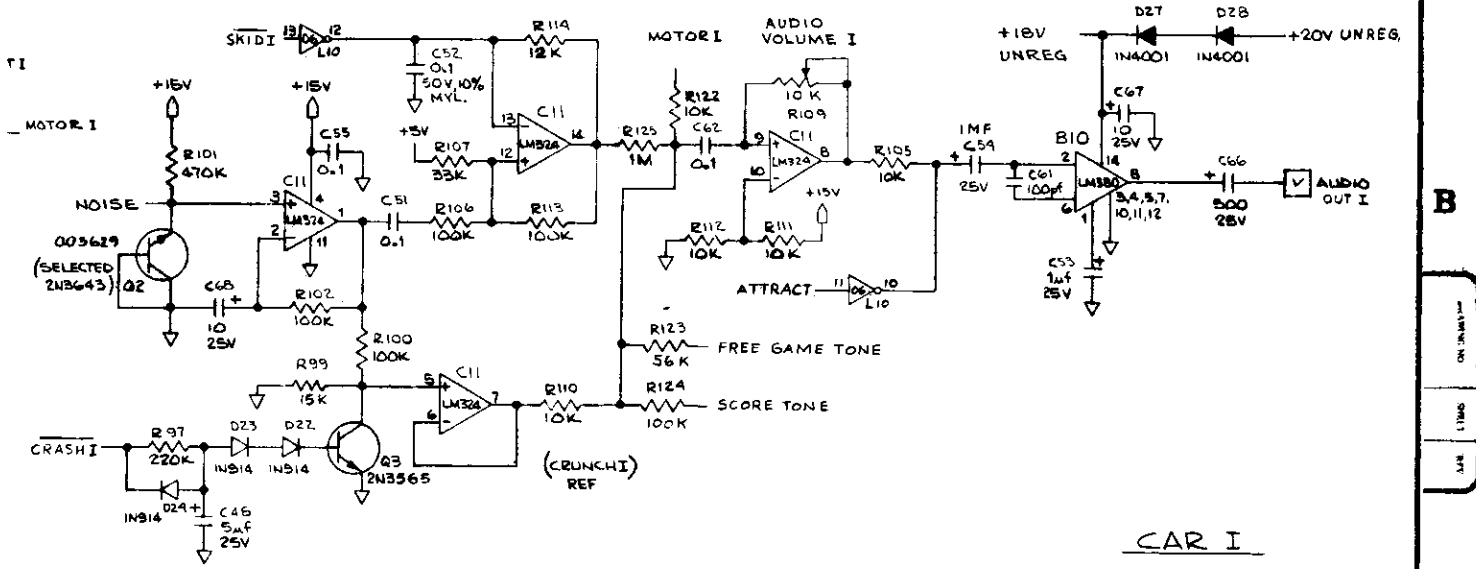
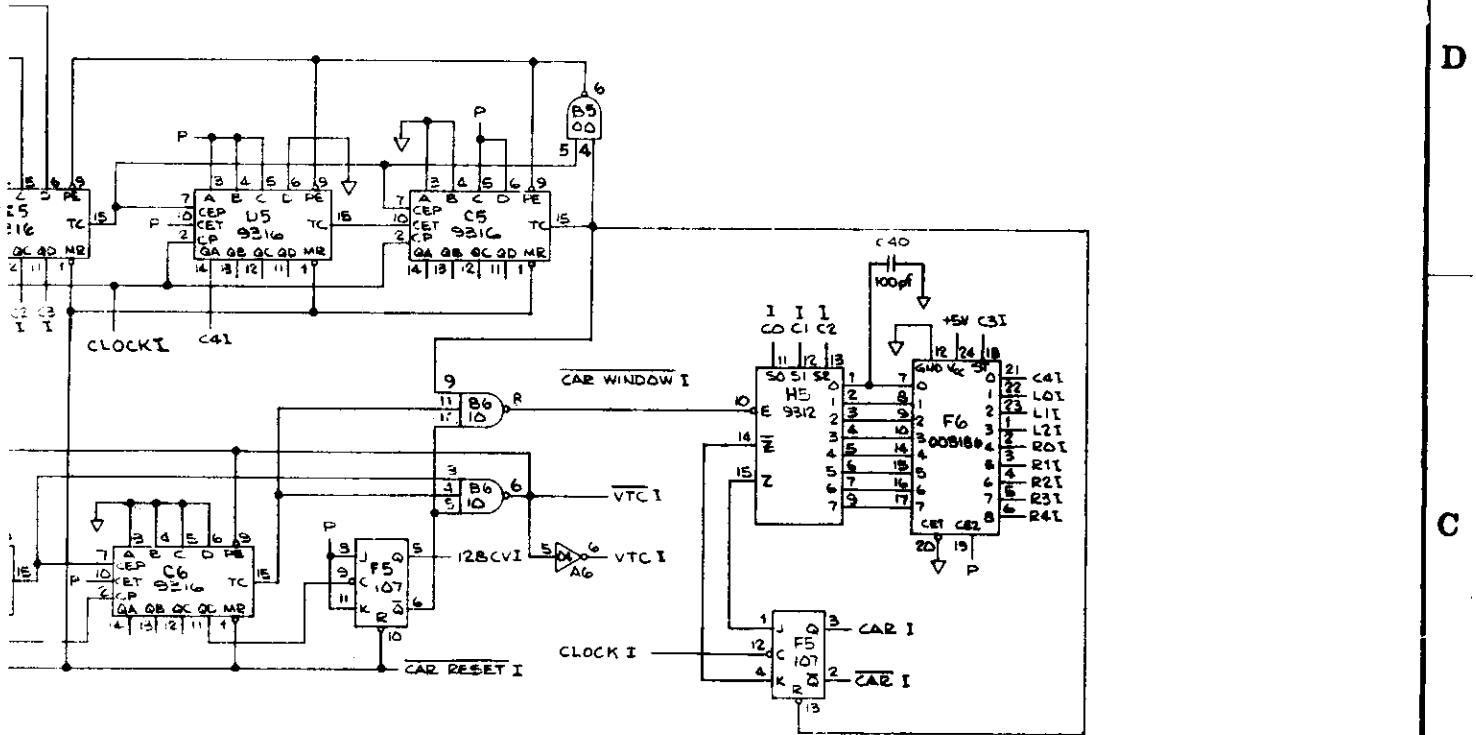

INTERPRET THIS DRAWING PER USAS 9145	DRAWN BY	DATE	 ATARI INCORPORATED 14600 Winchester Boulevard Los Gatos, California 95030
UNLESS OTHERWISE SPECIFIED DIMENSIONS ARE IN INCHES TOLERANCES ON	CHECKED		
FRACTIONS - 1/16 ... 1/4 ANGLES - 61° ... 0° SURFACE FINISH - ...	DESIGN ENGINEER		
MATERIAL	PROJECT ENGINEER		
	DOCUMENT CONTROL		TITLE SCHEMATIC CRASH N'SCORE
			REV D
			DRAWING 004256
			REV C
			SCALE
			SHEET 3 OF 4

NOTE TO ALL PERSONS RECEIVING THIS DRAWING: CONFIDENTIAL. Reproduction Forbidden without the specific written permission of Atari Inc., Los Gatos, California. This drawing is only conditionally issued, and neither conveys nor purports to convey any technical information, nor any right to reproduce this drawing or any part thereof, except for manufacturing purposes by vendors for Atari Incorporated and for manufacturing under the corporation's written license. No right to reproduce this drawing is granted or implied by this document unless written agreement with the subject matter thereof is in the possession.

D
C
B
A

8

7

6

5

D

C

B

A

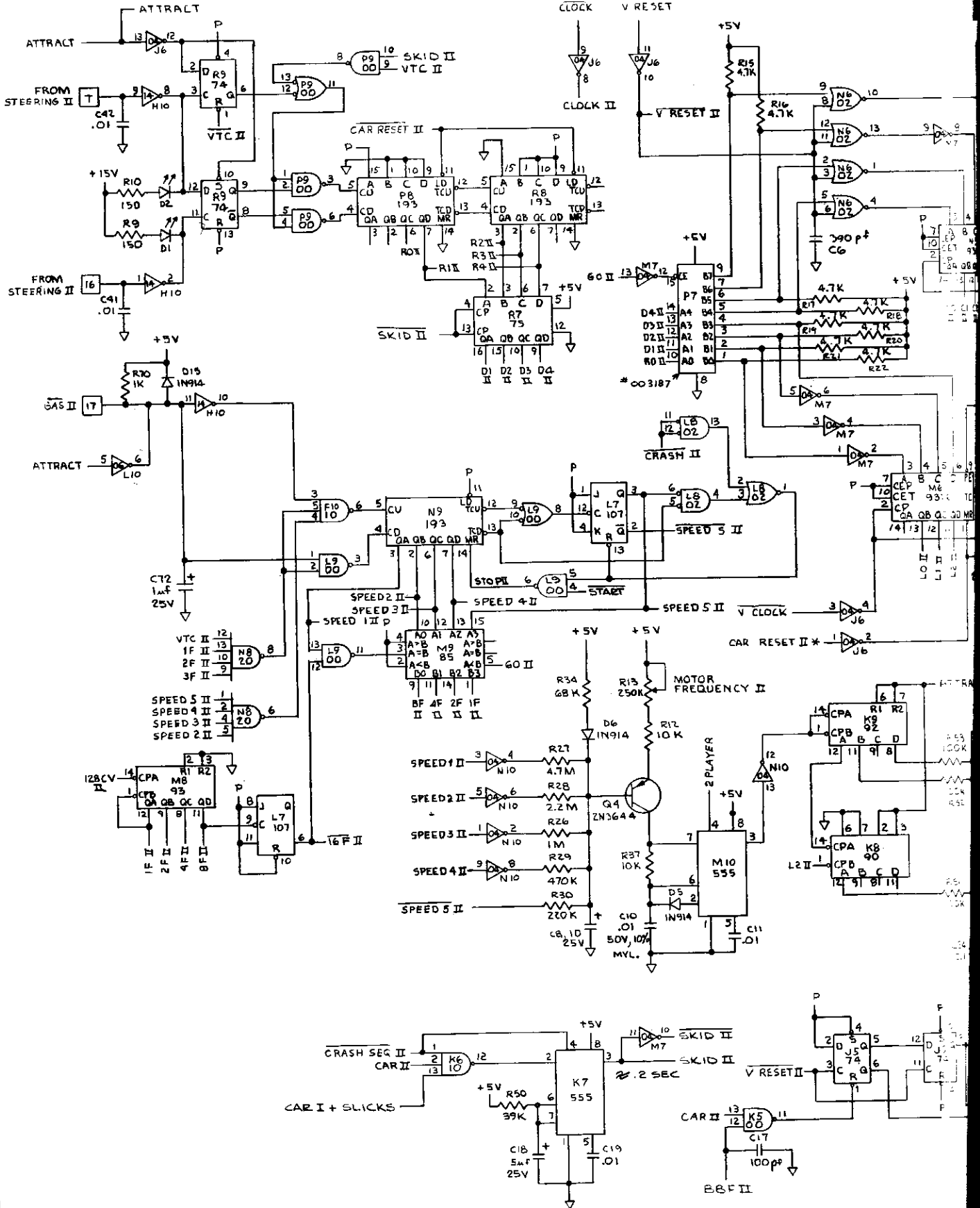

REVISIONS				
SYM	DESCRIPTION	INITIALS and DATE		
		DRAFTG	CHECK	ENCRG
M/F	SEE SMT 1			

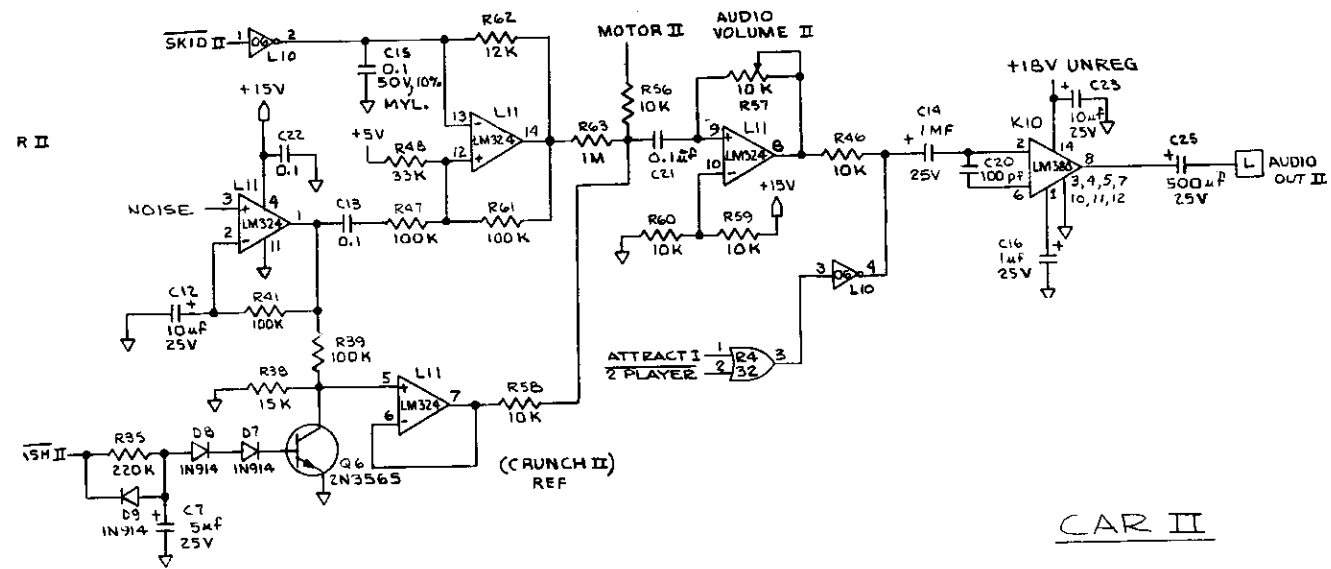
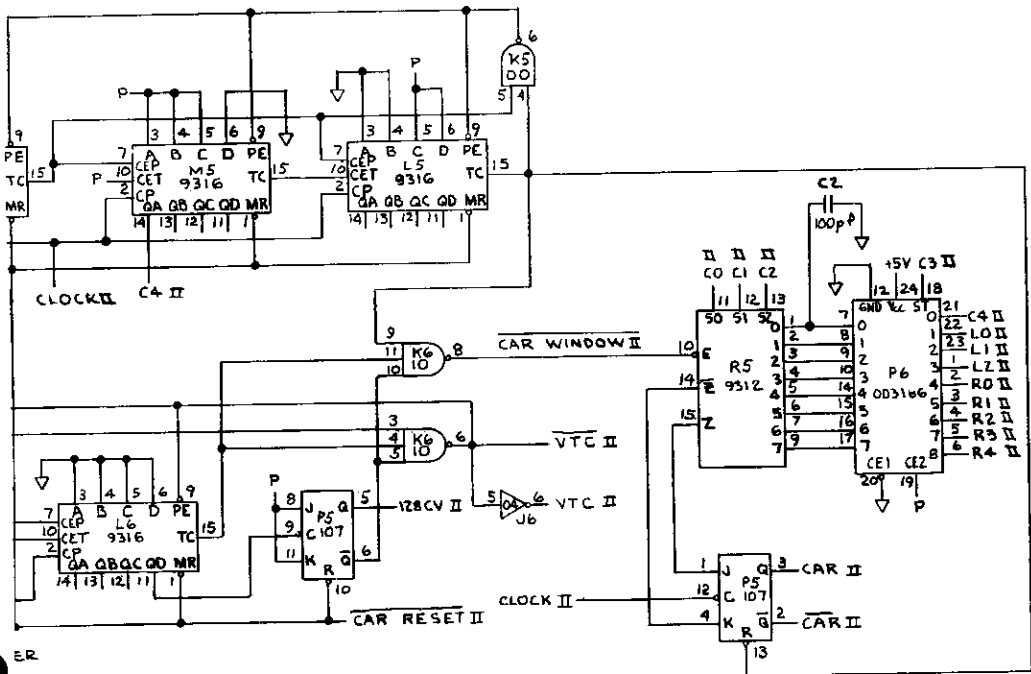

SEQ II
- CRASH II

NOTICE TO ALL PERSONS RECEIVING THIS DRAWING
 CONFIDENTIAL: Reproduction Forbidden without the specific written permission of Atari Inc., Los Gatos, California. This drawing is only conditionally loaned, and neither receipt nor possession thereof confers or assumes any right in, or license to use, the subject matter of the drawing or any design or technical information shown thereon, nor any right to reproduce this drawing or any part thereof, except for manufacture under the cooperation's written license, no right to reproduce this drawing is granted or the subject matter thereof unless by written agreement with or written permission from the corporation.

INTERPRET THIS DRAWING PER USASI Y14.5	DRAWN BY	DATE
UNLESS OTHERWISE SPECIFIED DIMENSIONS ARE IN INCHES TOLERANCES ON:	CHECKED	9/8/75
FRACTIONS = 1/16 .X = .1	DESIGN ENGINEER	
ANGLES = 45° .XX = .03	PROJECT ENGINEER	
SURFACE FINISH .XXX = .010	DOCUMENT CONTROL	
MATERIAL:	APPROVED	
NEXT ASSY	USED ON	
APPLICATION		

ATARI INCORPORATED 14600 Winchester Boulevard Los Gatos, California 95030	TITLE
SCHEMATIC	
CRASH N'S SCORE	
SIZE	DRAWING NO
D	004256
SCALE	REV
	C
	SHEET 4 OF 4

D

C

B

A

DRAWING NO
SHEET
REV



PARTS LIST SPECIFICATION

Drawn		Mech. Eng.	REV. C
Checked			
Proj. Eng.		Elec. Eng	

Rev.	Description	Date	Apprv.	Rev.	Description	Date	Apprv.
1		10/13/75					
A		10/21/75					
B	Rev 1763,1764,	11/11/75					
C	Rev Per ECN 1785,1786	12/2/75					

Item	Part Number	Qty.	DESCRIPTION
1	004257	1	Printed Circuit Board
2	37-7400	11	I.C. 7400 A3,B5,C9,E4,F9,H3,J4,K5,L9,P3,P9
3	37-7402	9	I.C. 7402 C8,E6,F1,F4,H2,L4,L8,N4,N6
4	37-7404	12	I.C. 7404 A1,A6,C3,C10,D7,E10,J3,J6,J9,M7,N10,R3
5	37-7406	1	I.C. 7406 L10
6	37-7408	3	I.C. 7408 F3,J8,MN1
7	37-7410	5	I.C. 7410 B6,D3,F10,K6,P2
8	37-7414	1	I.C. 7414 H10
9	37-7420	4	I.C. 7420 C4,E8,N3,N8
10	37-7430	1	I.C. 7430 B1
11	37-7432	1	I.C. 7432 R4
12	37-7448	1	I.C. 7448 J1
13	37-7474	14	I.C. 7474 A5,A7,A8,B3,DE1,H9,J5,J7,K3,K4,M4,N1,R2,R9
14	37-7475	2	I.C. 7475 H7,R7
15	37-7485	3	I.C. 7485 B4,D9,M9
16	37-7486	3	I.C. 7486 D4,M3,L3
17	37-7490	7	I.C. 7490 B8,K8,L1,L2,M1,M2,P10
18	37-7492	2	I.C. 7492 B9,K9
19	37-7493	5	I.C. 7493 A4,D1,D8,E1,M8
20	37-74107	6	I.C. 74107 C7,F5,FH1,L7,P1,P5
21	37-74153	3	I.C. 74153 F2,K1,K2
22	37-74192	1	I.C. 74192 E3
23	37-74193	7	I.C. 74193 E9,F8,H8,N9,P4,P8,R8
24	37-74279	2	I.C. 74279 MN2,N2
25	37-9312	4	I.C. 9312 H1,H5,J2,R5
26	37-9316	13	I.C. 9316 A2,B2,C2,C5,C6,D5,D6,E5,L5,L6,M5,M6,N5
27	37-9602	2	I.C. 9602 H4,R1
28	37-555	6	I.C. 555 B7,D10,K7,M10,R10
29	37-LM323	1	Reg LM323 + 5V
30	37-LM324	2	I.C. LM324 OP AMP C11,L11
31	37-LM340T-15	1	Reg LM340T-15 +15V or 7815 Q13
32	37-LM380	2	I.C. LM380 Audio AMP B10,K10

PARTS LIST SPECIFICATION

Page 2 of 3

Item	Part Number	Qty.	DESCRIPTION	
33	003186	2	Rom, RT8 Car Video	F6,P6
34	003187	2	P-Rom, RT8, Car Motion Code	F7,P7
35	004248	1	P-Rom, Crash 'N Score, Location Code	D2
36	004247	1	P-Rom, Crash 'N Score, Shape Code	E2
37	79-42424	2	24 pin I.C. Socket	
38	79-42116	4	16 pin I.C. Socket	
39	31-MR501	2	Diode MR501 Power	D10,D11
40	31-A14F	2	Diode A14F Power	D18,D19
41	31-1N4001	2	Diode 1N4001 Power	D27,D28
42	31-1N914	17	Diode 1N914	D3,D5-D9,D12,D15, D16,D17,D20-D26
43	33-2N3644	3	Transistor PNP 2N3644	Q1,Q4,Q9
44	34-2N3643	2	Transistor NPN 2N3643	Q7,Q8
45	34-2N3565	2	Transistor NPN 2N3565	Q3,Q6
46	003629	1	Selected NPN Noise Source 2N3643	Q2
47	35-MCR106	3	SCR Transistor MCR106	Q10,Q11,Q12
48	38-MV5013	5	Light Emitting Diode, Visible Red	D1,D2,D4,D13,D14
49	21-500103	2	Capacitor, Mylar, .01uf, 50V	C10,C49
50	21-500104	2	Capacitor, Mylar, .1uf, 50V	C15,C52
51	24-160808	1	Capacitor, Elect. 8000uf 16V	C45
52	24-250105	6	Capacitor, Elect. 1uf 25V	C14,C16,C53,C54
53	24-250505	4	Capacitor, Elect. 5uf 25V	C7,C18,C48,C59
54	24-250106	9	Capacitor, Elect. 10uf 25V	C5,C8,C9,C12,C23, C47,C56,C67,C68, C4,C38,C39
55	24-250107	3	Capacitor, Elect. 100uf 25V	C1
56	24-060257	1	Capacitor, Elect. 250uf 6V	C25,C66
57	24-250507	2	Capacitor, Elect. 500uf 25V	C57
58	24-250478	1	Capacitor, Elect. 4700uf 25V	C3,C11,C19,C36, C37,C41,C42,C50, C60,C69
59	27-250103	11	Capacitor, Ceramic .01uf 25V	C13,C21,C22,C24, C26-C35,C43,C44, C51,C55,C62,C63, C65,C70
60	27-250104	23	Capacitor, Ceramic .1uf 25V	C2,C17,C20,C40, C58,C61,C64 C6,C46
61	28-101101	6	Capacitor, Mica 100pf 100V	
62	28-101391	2	Capacitor, Mica 390pf 100V	
63	10-5101	3	Resistor, Carbon, 5%, 1/4W, 100 ohm	R75,R77,R79
64	10-5151	4	Resistor, " " " 150 ohm	R9,R10,R73,R74
65	10-5221	6	Resistor, " " " 220 ohm	R14,R32,R33,R66, R72,R76
66	10-5331	3	Resistor, " " " 330 ohm	R78,R118,R119
67	10-5471	4	Resistor, " " " 470 ohm	R24,R31,R65,R71
68	10-5102	16	Resistor, " " " 1K	R3,R7,R8,R25,R36, R69,R70,R95,R103,R104,R120,R121,R49,R54,R55,R64



PARTS LIST SPECIFICATION

Page 3 of 3

Item	Part Number	Qty.	DESCRIPTION
69	10-5272	4	Resistor, Carbon, 5%, 1/4W, 2.7K R126-R129
70	10-5152	1	Resistor, " " " 1.5K R23
71	10-5472	16	Resistor, " " " 4.7K R15-R22, R80-R87
72	10-5103	15	Resistor, " " " 10K R2, R12, R37, R46, R56, R58, R59, R60, R93, R98, R105, R110, R111, R112, R122
73	10-5123	2	Resistor, " " " 12K R62, R114
74	10-5153	2	Resistor, " " " 15K R38, R99
75	10-5333	3	Resistor, " " " 33K R1, R48, R107
76	10-5563	1	Resistor, " " " 56K R123
77	10-5683	2	Resistor, " " " 68K R34, R96
78	10-5393	2	Resistor, " " " 39K R50, R108
79	10-5104	17	Resistor, " " " 100K R5, R11, R39, R41, R47, R51, R52, R53, R61, R100, R102, R106, R113, R115, R116, R117, R124
80	10-5224	4	Resistor, " " " 220K R30, R35, R92, R97
81	10-5474	3	Resistor, " " " 470K R29, R91, R101
82	10-5105	4	Resistor, " " " 1 Meg R26, R63, R88, R125
83	10-5225	2	Resistor, " " " 2.2M R28, R90
84	10-5475	2	Resistor, " " " 4.7M R27, R89
85	17-54P0	1	Resistor, WW, 5%, 10W, 4 ohm R6
86	19-311103	2	Trim Pot, 10K ohm R57, R109
87	19-311254	2	Trim Pot, 250K ohm R13, R94
88	19-311105	1	Trim Pot, 1M ohm R4
89	66-024P1T	1	Dip Switch, 4SPST S2
90	69-001	1	Switch, DPDT S1
91	72-1406C	2	Screw, Mach, Pan Hd, Phil 4-40 x 3/8, CRES
92	75-016C	2	Washer, Flat #6, CRES
93	75-914C	2	Nut, Hex 4-40, CRES
94	75-054	2	Lockwasher, Int Star #4
95	75-056	2	Lockwasher, Int Star #6
96	75-916C	2	Nut, Mach, Hex, 6-32, CRES
97	78-06004	1	Heat Sink, Wakefield #680-.75A
98	78-16005	1	Silpad, Wafer, Insulator, To-3
99	90-101	1	Crystal 14.31818 Y1
100	72-1610C	2	Screw, Mach, Pan Hd, Phil, 6-32 x 5/8", CRES
101	10-5273	2	Resistor, Carbon, 5%, 1/4 W, 27K R67, R68
102	10-5333	1	Resistor, Carbon, 5%, 1/4 W, 330K R130



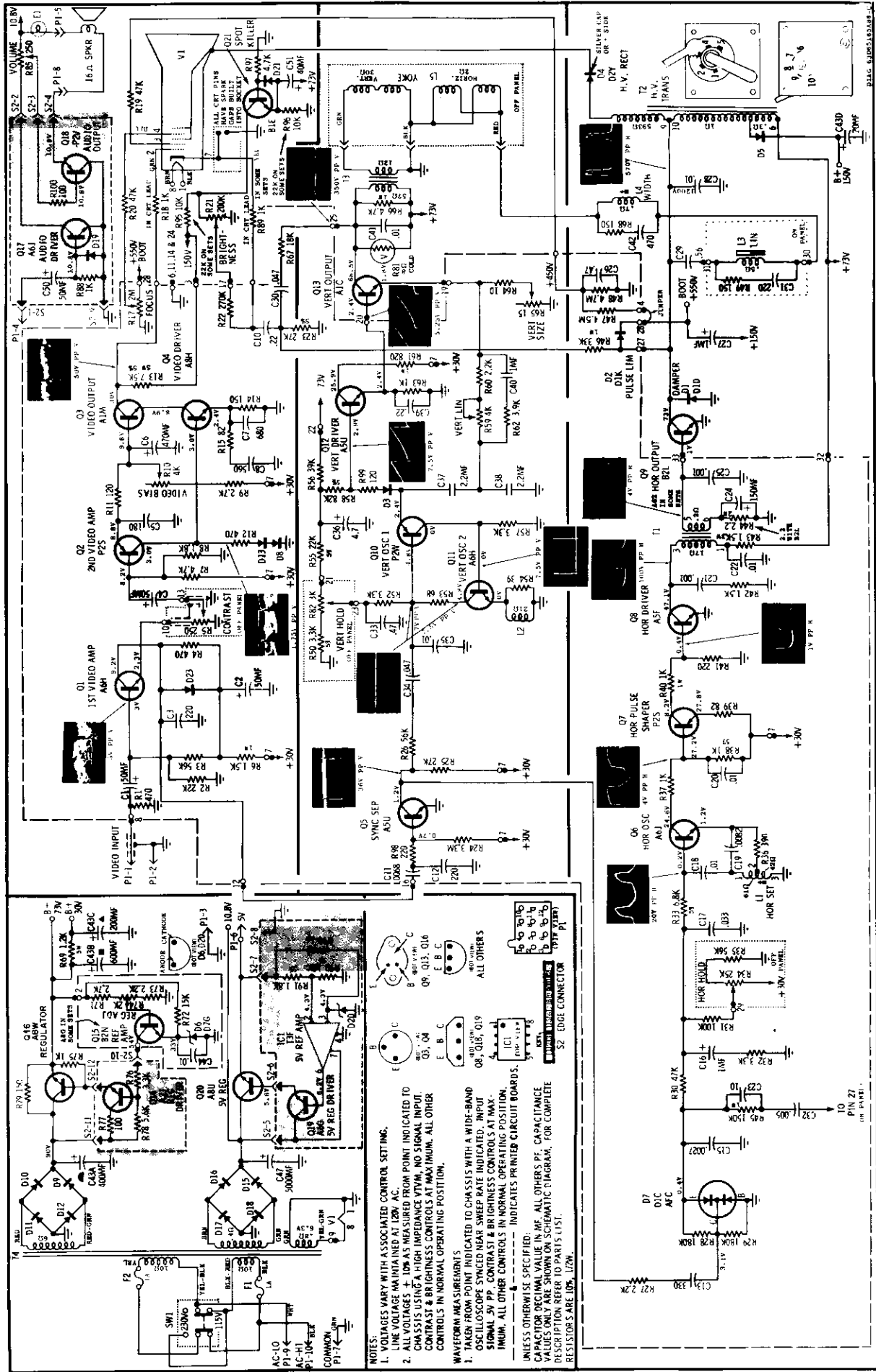

NOTES:

- VOLTAGES VARY WITH ASSOCIATED CONTROL SETTING. LINE VOLTAGE MAINTAINED AT 120V AC.
- ALL VOLTAGES \pm 10% AS MEASURED FROM POINT INDICATED TO CHASSIS USING A HIGH IMPEDANCE VTVM, NO SIGNAL INPUT. CONTRAST & BRIGHTNESS CONTROLS AT MAXIMUM. ALL OTHER CONTROLS IN NORMAL OPERATING POSITION.

WAVEFORM MEASUREMENTS:

- TAKEN FROM POINT INDICATED TO CHASSIS WITH A WIDE-RANGE OSCILLOSCOPE SYNCHRONIZED NEAR SWEEP RATE INDICATED. INPUT SIGNAL 5V PP. CONTRAST & BRIGHTNESS CONTROLS AT MAXIMUM. ALL OTHER CONTROLS IN NORMAL OPERATING POSITION.

UNLESS OTHERWISE SPECIFIED:

- CAPACITOR DECIMAL VALUE IN μ F. ALL OTHERS PER STANDARD DESCRIPTION REFER TO PARTS LIST.
- RESISTORS ARE 10% 1/2W.

Schematic, Motorola XM501/XM701 Monitor